

RUS Bulletin 1728F-806 Viewing Instructions

There are both bookmarks and links imbedded in this file.

Browsing with bookmarks

Bookmarks mark parts of a document for quick access.

To jump to a topic by using its bookmark:

1. The bookmarks are shown on the left side of the screen. If a triangle appears to the left of the bookmark, click the triangle to show or hide subordinate bookmarks.
2. To go to the destination specified by a bookmark, click the bookmark text or double-click the page icon to the left of the bookmark name.

Following links

The index in this publication uses links to allow the user to quickly go to the desired section.

To follow a link:

1. Move the pointer over a linked area. The pointer changes to a pointing finger when positioned over a link.
2. Click to follow the link.

General information:

You can use the buttons at the top of the screen for going from page to page. Also, by right-clicking your mouse, you will see a navigation box. For details, please see the Acrobat Reader help screens.



**United States
Department of
Agriculture**

Rural
Utilities
Service

RUS Bulletin
1728F-806
(D-806)

June 2000

Specifications and Drawings for Underground Electric Distribution

UNITED STATES DEPARTMENT OF AGRICULTURE
Rural Utilities Service

BULLETIN 1728F-806

SUBJECT: Specifications and Drawings for Underground Electric Distribution

Incorporated by reference (IBR) in 7 CFR Part 1728

TO: RUS Electric Staff
RUS Electric Borrowers

DATES:

Effective Date: June 26, 2000*.

Incorporation by Reference: IBR approved by the Director, Office of the Federal Register June 26, 2000.

Expiration Date: Date of change in 7 CFR Part 1728 by rulemaking.

OFFICE OF PRIMARY INTEREST: Electric Staff Division

FILING INSTRUCTIONS: This bulletin replaces Bulletin 50-6 (D-806), Specifications and Drawings for Underground Electric Distribution, dated February 27, 1990. Discard Bulletin 50-6 and replace it with this bulletin, RUS Bulletin 1728F-806.

AVAILABILITY: This bulletin is available on the RUS electric web page at:
<http://www.usda.gov/rus>.

PURPOSE: This bulletin contains complete specifications setting forth the RUS requirements for constructing rural underground electric distribution systems using state-of-the-art materials, equipment, and construction methods. This information is incorporated by reference in 7 CFR Part 1728.



Assistant Administrator
Electric Program



Date

TABLE OF CONTENTS

1. General	1
2. Storage of Material and Equipment	1
3. Handling of Cable	2
4. Plowing	2
5. Special Requirements for Coordination Between Owner and Contractor Where Cable is to be Installed by Plowing	3
6. Trenching	3
7. Installing Cable in Trench	4
8. Minimum Bending Radius of Cable	5
9. Conduit	5
10. Tagging of Cables at Termination Points	5
11. Splices	5
12. Primary Cable Termination and Stress Cones	5
13. Special Precautions for Cable Splices and Terminations	6
14. Secondary and Service Connections	6
15. Pedestals	6
16. Inspection and Inventory of Buried Units	7
17. Backfilling	7
18. Equipment Pads.....	7
19. Transformers.....	7
20. Equipment Enclosures.....	7
21. Utility Safety Signs	8
22. Sacrificial Anodes	8
23. Grounding.....	8
24. Cable Location Markers	8
25. Installed Cable and Acceptance Tests.....	8

Attachment A: Index of Drawings

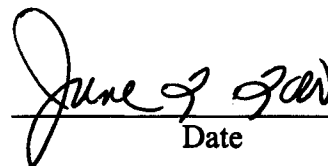
Attachment B: Construction Drawings

INDEX:

ASSEMBLIES:

Underground Distribution – Bul. 1728F-806

SPECIFICATIONS AND STANDARDS:

Construction Specifications and Drawings – Bul. 1728F-806

Underground Electric Distribution – Bul. 1728F-806

UNDERGROUND DISTRIBUTION:

Underground Rural Distribution – Bul. 1728F-806

1. GENERAL

1.1 These specifications provide for the construction of underground distribution power facilities as specified by the owner. The owner is the organization contracting for the services and, when used in connection with RUS financed facilities, is synonymous with the term borrower as defined in §1710.2.

1.2 It is the responsibility of the borrower to ensure that all construction work shall be accomplished in a thorough and workmanlike manner in accordance with the staking sheets, plans and specifications, and the construction drawings.

1.3 If construction work is performed by the Owner's force account crews instead of a contractor, any reference to "Contractor" apply to the force account crews.

1.4 The provisions of section §1724.50, Compliance with National Electrical Safety Code (NESC) apply to all borrower electric system facilities regardless of the source of financing.

- a. A borrower must ensure that its electric system, including all electric distribution, transmission, and generating facilities, is designed, constructed, operated, and maintained in accordance with all applicable provisions of the most current and accepted criteria of the NESC and all applicable and current electrical and safety requirements of any State or local government entity. Copies of the NESC may be obtained from the Institute of Electrical and Electronic Engineers, Inc., 345 East 47th Street, New York, New York 10017-2394. This requirement applies to the borrower's electric system regardless of the source of financing.
- b. Any electrical standard requirements established by RUS are in addition to, and not in substitution for or a modification of, the most current and accepted criteria of the NESC and any applicable electrical or safety requirements of any State or local governmental entity.
- c. Overhead distribution circuits shall be constructed with not less than the Grade C strength requirements as described in Section 26, Strength Requirements, of the NESC when subjected to the loads specified in NESC Section 25, Loadings for Grades B and C. Overhead transmission circuits shall be constructed with not less than the Grade B strength requirements as described in NESC Section 26.

2. STORAGE OF MATERIAL AND EQUIPMENT: It is the responsibility of the borrower to ensure that all material and equipment to be used in construction must be stored so as to be protected from deteriorating effects of the elements. If outdoor storage cannot be avoided, the material and equipment must be stacked on supports well above the ground line and protected from the elements as appropriate, and with due regard to public safety.

3. HANDLING OF CABLE: It is the responsibility of the borrower to ensure that the cable shall be handled carefully at all times to avoid damage, and shall not be dragged across the ground, fences or sharp projections. Care shall be exercised to avoid excessive bending of the cable. The borrower shall ensure that the ends of the cable be sealed at all times against moisture with suitable end caps. Where it is necessary to cut the cable, the ends will be terminated or sealed immediately after the cutting operation.

4. PLOWING

4.1 When cables are to be installed by plowing, it is the responsibility of the borrower to ensure that the plowing equipment be subject to the approval of the Owner and the public authorities having jurisdiction over highway and road rights-of-way. The plow must be provided with a means to assure positive holddown of the plow blade to provide proper depth at all times.

4.2 The design of the plowshare must ensure that the cable passing through the plow will not be bent in a radius less than 12 times the outside diameter of the cable. The equipment must be capable of extending the plow a minimum of 6 inches below the specified depth under all terrain conditions of plow utilization.

4.3 The borrower must ensure that equipment and construction methods used during construction cause minimum displacement of the soil. The slot made in the soil by the cable plows must be closed immediately by driving a vehicle track or wheel over the slot or by other suitable means.

4.4 Starting and terminating points of the plowing operation must be excavated prior to cable installation to reduce possible cable damage and to assure sufficient burial depth.

4.5 During the plowing operation, care is to be exercised to feed the cable or wire into the ground through the plow loosely and at minimum tension. Besides using proper equipment and construction methods, supervision by the borrower or the borrower's representative shall be furnished at all times at the site of plowing operations to assure compliance with these specifications.

4.6 If, during the plowing operation, the plow should strike a buried object or rock that would stop the equipment and necessitate removal of the plow from the ground, the plow must be removed from the ground carefully and, if practical, without backing the plow. If it should be necessary to back the plow to remove it from the ground, the cable must be uncovered a sufficient distance back for inspection by the Owner to determine whether the cable or wire has been damaged.

4.7 The cable must be inspected carefully as it is payed out from the reel to be certain that it is free from visible defects. Every instance of damaged cable observed at any time, whether prior to installation, during installation, or when discovered by test or observation subsequent to installation in plant, shall be immediately called to the attention of the Owner. Repair or correction of such damage must be completed promptly and in accordance with the written instruction of the Owner. The location of any such repair must be indicated on the staking sheet.

5. SPECIAL REQUIREMENTS FOR COORDINATION BETWEEN OWNER AND CONTRACTOR WHERE CABLE IS TO BE INSTALLED BY PLOWING

5.1 It is the responsibility of the borrower to ensure that the Contractor and the Owner shall jointly review the staking sheets prior to the start of construction. At that time, the Contractor shall propose any desirable changes or clarifications. These changes, if approved by the Owner, shall be made and recorded on the staking sheets. No changes on the staking sheets shall be made by the Contractor without the prior written approval of the Owner. A representative of the Owner shall remain in the immediate vicinity of the plowing operations at all times and shall consider and possibly approve any acceptable changes proposed by the Contractor. A representative of the Owner shall also inspect any damage to cable and approve acceptable methods of repair or correction of such damage in accordance with the provisions of these specifications.

5.2 In the event that rock is encountered during the plowing operation so that the buried cable cannot be installed to the required minimum depths in soil, the Contractor shall determine for the Owner the nature and extent of the rock encountered. Based on this information, the Owner shall determine whether the cable is to be rerouted, trenched in rock or a change made to aerial construction. This decision shall be made promptly, and appropriate changes in units shall be made on the staking sheets. Such changes shall be in writing, dated, and initialed by the Owner.

5.3 Due to the necessity of making on-the-spot corrections and changes on staking sheets, it may not be possible for the Owner to issue revised staking sheets to the Contractor in all cases. When changes are made, dated, and initialed by the Owner on a set of the Contractor's staking sheets, it shall be the Contractor's responsibility to transfer these changes to all other sets of staking sheets being used by the Contractor for construction purposes.

5.4 The Contractor shall provide a competent representative to work with the Owner on the inventory and inspection of buried cable units. The inventory of buried cable will be made as soon after the plowing operation as practical to avoid later disagreements on the quantity of cable installed when changes are required in the project.

6. TRENCHING

6.1 It is the responsibility of the borrower to ensure that all trenching depths specified are minimum as measured from the final grade to the top surface of the cable. The routing must be as shown on the staking sheets and plans and specifications unless conditions encountered are such that changes are necessary to accomplish the work. In such event, the Owner shall be notified promptly. If rock or other difficult digging is involved, the Contractor shall determine the nature and extent of the difficulty, and the Owner shall determine whether rerouting, rock trenching, plowing or other changes are necessary. Loose soil or crumbly rock shall not be considered as "difficult digging." The trench widths specified are minimum and should be increased as necessary to obtain the required depths in loose soils.

6.2 Where trenches are intended for more than one cable, particular care must be taken to provide for extra depth and width to allow for soil falling into the trench during the laying of the first cables.

6.3 Care shall be exercised to minimize the likelihood of waterflow since this may cause trench damage and reduction in trench depth. If this occurs, the trench must be cleared to the specified depth before installing the cable.

6.4 All trenches must follow straight lines between staked points to the greatest extent possible. Secondary and service trenches must extend in a straight line from takeoff points wherever possible. The trenches must be dug so that the bottom has a smooth grade. Large rocks, stones and gravel in excess of 1 inch must be removed from the bottom of the trench. Where this cannot be accomplished, a 2 inch bed of sand or clean soil must be placed in the bottom of the trench.

6.5 Construction shall be arranged so that trenches may be left open for the shortest practical time to avoid creating a hazard to the public and to minimize the likelihood of collapse of the trench due to other construction activity, rain, accumulation of water in the trench, etc.

7. INSTALLING CABLE IN TRENCH

7.1 It is the responsibility of the borrower to ensure that the cable must be placed in the trench as soon after the trenching operation as feasible. Wherever possible, cable must be payed out from the reel mounted on a moving vehicle or trailer. The reel must be supported so that it can turn easily without undue strain on the cable. The cable must be carefully placed in the trench by hand. All cable placement will be done under constant supervision by the borrower or the borrower's representative who assure that no damage to the cable occurs.

7.2 The cable must be inspected carefully as it is removed from the reel in laying operations to be certain that it is free from visible defects. The Owner shall decide upon corrective action when defects are discovered.

7.3 Where more than one cable is to be placed in a trench, the spacings required by the specifications must be observed. Care must be taken that any soil falling into the trench during the laying of the first cable does not reduce the clearances of the last cable below that specified. Should this occur, the excess soil must be removed carefully by hand or with equipment that will not damage the installed cables.

7.4 Sufficient slack, and in no case less than 24 inches, must be left at all risers, transformer pads, pedestals and terminal points so that movements of cable after backfilling will not cause damaging strain on the cable or terminals. The cable trench must be mechanically compacted at least 36 inches from all riser poles, pads, pedestals and terminal points.

7.5 The ends of all secondary cable terminated below ground must be long enough to reach at least 12 inches above the top of the underground enclosure.

8. MINIMUM BENDING RADIUS OF CABLE: It is the responsibility of the borrower to ensure that the minimum bending radius of primary cable is 12 times the overall diameter of the cable. The minimum bending radius of secondary and service cable is six times the overall diameter of the cable. In all cases the minimum radius specified is measured to the surface of the cable on the inside of the bend. Cable bends must not be made within 6 inches of a cable terminal base.

9. CONDUIT: It is the responsibility of the borrower to ensure that all exposed ends of conduit must be plugged during construction to prevent the entrance of foreign matter and moisture into the conduit. Burrs or sharp projections which might injure the cable must be removed. Riser shield or conduit must extend at least 18 inches below grade at all riser poles. If full round conduit is used as a riser shield, an end bell must be installed on the lower end to prevent damage to the cable.

10. TAGGING OF CABLES AT TERMINATION POINTS: As the cables are laid, it is the responsibility of the borrower to ensure that they must be identified and tagged. The identification must be of a permanent type, such as that done on plastic or corrosion resistant metal tags. The tag must be securely attached to the cable. Paper or cloth tags are not acceptable.

11. SPLICES

11.1 It is the responsibility of the borrower to ensure that cable splices must be of the pre-molded rubber, heat-shrink, or cold-shrink type, of the correct voltage rating and must be installed in accordance with the splice manufacturer's instructions. Splices that depend solely on tape for a moisture barrier must not be used.

11.2 Not more than one splice may be permitted for each 2000 feet of cable installed unless authorized by the Owner. No bends may be permitted within 12 inches of the ends of a splice. The cable or circuit numbers and the exact location of all splices must be noted on the staking sheets (as built).

12. PRIMARY CABLE TERMINATION AND STRESS CONES: It is the responsibility of the borrower to ensure that prefabricated stress cones or terminations must be installed in accordance with the manufacturer's instructions at all primary cable terminals. They must be suitable for the size and type of cable that they are used with and for the environment in which they will operate. Any indication of misfit, such as a loose or exceptionally tight fit, must be called to the Owner's attention. The outer conductive surface of the termination must be bonded to the system neutral. A heat-shrink or cold-shrink sleeve must be installed to seal between the body of the termination and the cable jacket.

13. SPECIAL PRECAUTIONS FOR CABLE SPLICES AND TERMINATIONS: It is the responsibility of the borrower to ensure that a portable covering or shelter must be available for use when splices or terminations are being prepared and when prefabricated terminations are being switched. The shelter must be used as necessary to keep rain, snow and windblown dust off the insulating surfaces of these devices. Since cleanliness is essential in the preparation and installation of primary cable fittings, care shall be exercised to prevent the transfer of conducting particles from the hands to insulating surfaces. Mating surfaces must be wiped with a solvent such as denatured alcohol to remove any possible accumulation of dirt, moisture or other conducting materials. A silicone grease or similar lubricant should be applied afterwards in accordance with the manufacturer's recommendations. Whenever prefabricated cable devices are opened, the unenergized mating surfaces must be lubricated with silicone grease before the fittings are reconnected.

14. SECONDARY AND SERVICE CONNECTIONS

14.1 It is the responsibility of the borrower to ensure that a suitable inhibiting compound must be used with all secondary and service connections.

14.2 All secondary cable connections located below grade or in secondary pedestals must be made with pre-insulated secondary connector blocks. Diving bells with open terminals, insulating boots or moisture barriers that depend solely on tape are not acceptable.

14.3 All transformer secondary phase terminal connections must be completely insulated. If the secondary phase terminals are threaded studs, the connection must be made with a pre-insulated secondary transformer connection block. If the transformer secondary phase terminals are insulated cable leads, connection must be made with a pre-insulated secondary connector block or with a secondary prefabricated splice when the transformer leads continue directly to the service.

14.4 If a transformer is so large that it must have secondary spades, the spades must be taped or otherwise insulated. Boots used for insulation must be taped so that they cannot be readily slipped off.

14.5 Secondary connections to terminals of pole-mounted transformers must be made so that moisture cannot get inside the cable insulation. This may be accomplished by covering the terminals and bare conductor ends with an appropriate moisture sealant or providing a drip loop.

14.6 The secondary connections and insulation must have accommodations for all future and existing services as shown on the plans and specifications.

15. PEDESTALS: Where required, it is the responsibility of the borrower to ensure that pedestal stakes must be driven vertically into the bottom of the trench before cables are placed, and shall be located as shown on the staking sheets. Pedestal posts and supporting stakes must be in place before the cable is installed. All pedestals should be approximately at the same height above finished grade.

16. INSPECTION AND INVENTORY OF BURIED UNITS: Before any backfilling operations are begun, it is the responsibility of the borrower to ensure that the Contractor and Owner shall jointly inspect all trenches, cable placement, risers, pedestal stakes, and other construction that will not be accessible after backfilling, and an inventory of units shall be taken. If corrections are required, a second inspection shall be made after completion of the changes.

17. BACKFILLING

17.1 It is the responsibility of the borrower to ensure that the first 6 inches of trench backfill shall be free from rock, gravel or other material which might damage the cable jacket. In lieu of cleaning the trench, the Contractor may, at the Contractor's option, place a 2 inch bed of clean sand or soil under the cable and 4 inches of clean soil above the cable. Cleaned soil backfill when used shall contain no solid material larger than 1 inch. This soil layer must be carefully compacted so that the cable will not be damaged.

17.2 Backfilling must be completed in such a manner that voids will be minimized. Excess soil must be piled on top and must be well tamped. All rock and debris must be removed from the site, and any damage to the premises repaired immediately.

17.3 Pieces of scrap cable or other material remaining after installation must not be buried in the trench as a means of disposal.

18. EQUIPMENT PADS: It is the responsibility of the borrower to ensure that the site for the pad shall be on undisturbed earth adjacent to but not over the trench. The site shall be cleared of all debris and excavated to the specified depth. Gravel or sand may be added to the site and thoroughly compacted. The pad shall be installed level at the specified elevation.

19. TRANSFORMERS: It is the responsibility of the borrower to ensure that transformers shall be handled carefully to avoid damage to the finish and shall be positioned in accordance with the staking sheets and the plans and specifications. Only qualified and experienced personnel shall be allowed to make connections and cable terminations.

20. EQUIPMENT ENCLOSURES: It is the responsibility of the borrower to ensure that excavations for sleeve-type transformer pads and other below-grade enclosures shall be made so as to disturb the surrounding earth as little as practical. Enclosures shall be installed with side walls plumb. When enclosures are of fiber, plastic, or other semiflexible material, backfilling should be done with covers in place and with careful tamping so as to avoid distortion of the enclosure. When installation is complete, the cover of the enclosure shall not be lower than and not more than 2 inches higher than the grade specified by the Owner. Soil in the immediate vicinity shall be tamped and sloped away from the enclosure. At the Owner's option, the excess soil shall be removed from the site or spread evenly over the surface of the ground to the satisfaction of the Owner.

21. UTILITY SAFETY SIGNS: It is the responsibility of the borrower to ensure that utility safety signs must be in accordance with ANSI Z535.2, Environmental and Facility Safety Signs, and shall be applied in accordance with RUS drawings. Copies of the ANSI Z535.2 may be obtained from the National Electrical Manufacturers Association (NEMA), 1300 North 17th Street, Suite 1847, Rosslyn, Virginia 22209.

22. SACRIFICIAL ANODES: It is the responsibility of the borrower to ensure that sacrificial anodes specified shall be installed with backfill package intact and connecting leads positioned for proper connection after the equipment is in place. Anodes shall neither be moved, positioned, lifted, nor lowered into place by pulling on the connecting leads.

23. GROUNDING

23.1 It is the responsibility of the borrower to ensure that all neutral conductors, grounding electrodes, sacrificial anodes and groundable parts of equipment shall be interconnected. All interconnections shall be made as shown on the construction drawings. A copper-clad or galvanized steel ground rod with minimum length of 8 feet shall be installed at all equipment locations as shown in the construction drawings and at all cable splices and taps.

23.2 All pad-mounted equipment enclosures, including transformers, shall be grounded in such a manner that two separate grounding paths exist between the enclosure and the grounding rod(s).

24. CABLE LOCATION MARKERS: It is the responsibility of the borrower to ensure that location of permanent cable markers shall be as shown on the staking sheets.

25. INSTALLED CABLE AND ACCEPTANCE TESTS

25.1 It is the responsibility of the borrower to ensure that:

- a. Continuity: After installation of the cable and prior to the high potential test specified below, authorized personnel shall perform a simple continuity test on the system. This can easily be accomplished by grounding the conductor at the source and checking for continuity from the end of each tap with an ohmmeter or with a battery and ammeter.
- b. High Potential: After successful continuity tests, authorized personnel should perform high potential tests on each length of cable, with terminations in place but disconnected from the system.

25.2 The installation shall withstand for a minimum of 15 minutes a DC test potential as follows:

Primary URD Cable (XLP-TR, and EPR)		
<u>Rated Voltage</u>	<u>Insulation Thickness Inches</u>	<u>Field DC Acceptance Test Voltage</u>
15 kV	.220	64.0 kV
25 kV	.260	80.0 kV
25 kV	.345	100.0 kV

The voltage may either be increased continuously or in steps to the maximum test value:

- a. If increased continuously, the rate of increase of test voltage should be approximately uniform and increasing to maximum voltage in not less than 10 seconds and in not more than approximately 60 seconds.
- b. If applied in steps, the rate of increase of test voltage from one step to the next should be approximately uniform. The duration at each step shall be long enough for the absorption current to attain reasonable stabilization (1 minute minimum). Current and voltage readings should be taken at the end of each step duration. The number of steps should be from five to eight.

25.3 **Warning:** A hazardous voltage may still exist on the cable after the above testing has been completed. Therefore, before handling the cable, it is the responsibility of the borrower to ensure that the conductor shall be grounded to permit any charge to drain to earth.

Attachment A

INDEX OF DRAWINGS

Primary Terminal Pole Assemblies:

UA1	Single Phase Cable Deadend Terminal Pole
UA2	Single Phase Cable Deadend Terminal Pole
UA3	Single Phase Cable Tangent Terminal Pole
UB1	Vee-Phase Cable Terminal Pole with Cutouts and Crossarm Mounting Arresters
UB2	Vee-Phase Cable Terminal Pole with Cutouts and Bracket Mounting Arresters
UB3	Vee-Phase Cable Terminal Pole without Cutout, with Crossarm Mounting Arresters
UB4	Vee-Phase Cable Terminal Pole without Cutout, with Bracket Mounting Arresters
UC1	Three Phase Cable Terminal Pole with Cutouts and Crossarm Mounting Arresters
UC2	Three Phase Cable Terminal Pole with Cutouts and Bracket Mounting Arresters
UC2-1	Three Phase Cable Deadend Terminal Pole
UC2-2	Three Phase Cable Tangent Terminal Pole
UC5-1	Three Phase Cable Deadend Terminal Pole with Disconnect Switches
UC6-1	Three Phase Cable Tangent Terminal Pole with Disconnect Switches

Transformer Assemblies:

UG6, UG6B,	Single Phase Pad-Mounted Transformer (Radial Feed)
UG7, UG7B	Single Phase Pad Mounted Transformer (Loop Feed)
UG17, UG17B	Three Phase Pad Mounted Transformer (Radial Feed)
UG17-2, UG17-2B	Three Phase Pad Mounted Transformer (Loop Feed)
UG17-3, UG17-3B	Three Phase Pad Mounted Loop Feed Transformer with Radial Feed

Secondary Assemblies:

UJ1, UJ2	Secondary Connector Blocks
UK5	Secondary Pedestal Underground Cable
UK6	Secondary Handhole Underground Cable

Pad Assemblies:

UM1-5C, UM1-5NC	Pad Assemblies
UM1-6C	Three Phase Transformer Concrete Pads
UM1-7C, UM1-7NC	Ground Sleeve Assembly

Sectionalizing Assemblies:

UM3-14	Single Phase Sectionalizing Enclosure
UM3-44, UM3-45	Single Phase Pad Mounted Sectionalizer or Recloser
UM3-46	Three, Single Phase Pad Mounted Reclosers

UM3E	Fuse/Switch Enclosure Installation
UM3E-1, UM3E-2	Single Pole Switching 200 AMP Fuse Enclosure Installation Wiring Diagrams (Single Phase and Two Phase)
UM3E-3	Fuse Enclosure (200 - 600 AMP) Wiring Diagrams (Three Phase)

Secondary Terminal Pole Assemblies:

UM5	Secondary Cable Terminal Pole
UM5-6, UM5-6A	Secondary Cable Terminal to Meter Base

Miscellaneous Accessories:

UM6-1 – UM6-8 Miscellaneous Accessories

Regulator Assembly:

UM7-1	Single Phase Regulator Assembly with By-Pass Switching Function Underground to Underground
-------	---

Metering Assemblies:

UM8	Meter Installation Underground Source
UM8-2	Meter Pedestal Wood Post
UM8-3 UM8-3A	Trough Type Meter Pedestal
UM8-4, UM8-4A	Meter & Switch Installation Underground Source
UM8-5	Pad Mounted Switch Installation Underground Source
UM8-6	C.T. Meter Installation Single Phase
UM8-7	C.T. Meter Installation Three Phase

Miscellaneous Assemblies:

UM9-2 Pad Mounted Switched Capacitor Enclosure

UM12 Cable Route Marker

Corrosion Control Assemblies:

UM27-1 Sacrificial Anode for Cable Splice Protection
(Bare to Jacketed Cable)

UM27-2 Sacrificial Anode for Equipment Ground Protection

UM27-3 Sacrificial Anode for Cable Ground Protection

UM28 Test Station

Sectionalizing Assembly:

UM33 Multi Phase Sectionalizing Enclosure Pad or Sleeve
Mounted

Grounding Assemblies:

UM48-1 Grounding Assembly for Pad Mounted Single Phase
Transformers and Enclosures

UM48-2 Grounding Assembly for Pad Mounted Multi Phase
Transformers and Enclosures

UM48-3 Grounding Assembly for Underground Primary Cable

UM48-4 Grounding Assembly for Underground Primary Cable
(with Test Station)

UM48-5 Grounding Grid for Pad Mounted Equipment
Installation

UM48-6 Grounding Array for Pad Mounted Equipment
Installation

Conduit and Trenching Assemblies:

UR2 to Trenches for Direct Burial Cables
UR2-2

UR2-3 to Trenches for Direct Burial Cables
UR2-5

UR2-NT Trenches for Direct Burial Cable
UR2-ST

Guideline Drawings:

UX1 Open Delta Connection with Single Phase Pad Mount
 Transformers

UX2 Single Phase Pad Mounted Transformer Deferred Unit
 Pedestal Type

UX3 Single Phase Padmounted Transformer Deferred Unit
 Pad-Sleeve Type

UX4 Installation of Neutral Connection in Above Grade
 Pedestal

UX5 Sectionalizing Pedestal Grounding

UX7 Location Methods for Below Grade Enclosure

UX8 Temporary Primary or Secondary Cable Termination
 for Future Use

UX11 Connection of Terminator/Arrester to Overhead Line

Attachment B

Construction Drawings

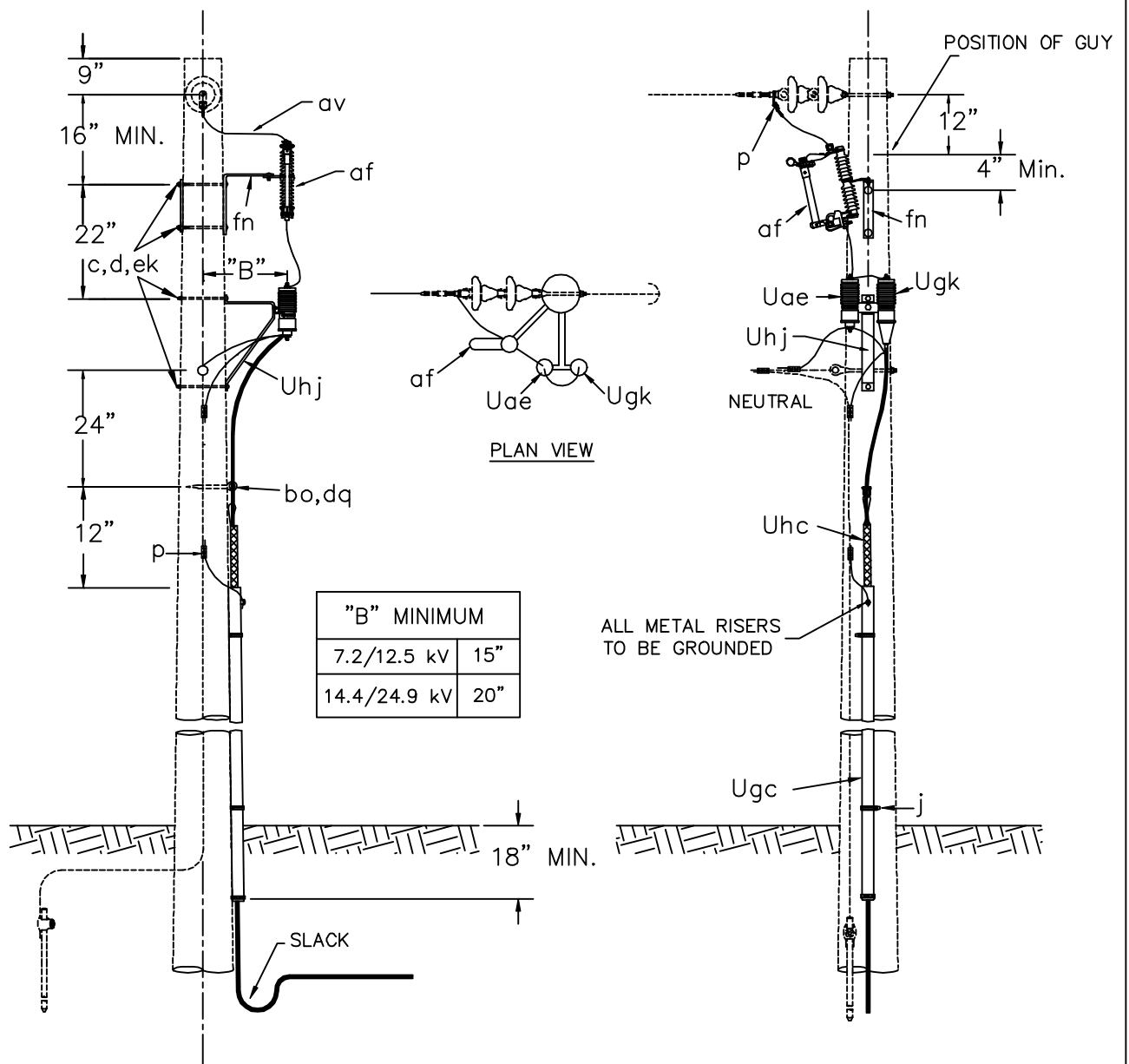

ITEM	QTY.	MATERIAL
c	4	Bolt, machine, 5/8" x required length.
d	4	Washer, square 2 1/4".
j		Screws, lag 1/2" X 4" as required.
p		Connectors, as required.
af	1	Fuse link.
af	1	Cutout
av		Jumpers, as required.
bo	1	Anchor, shackle. Do not use if drive hook is used.
dq	1	Eye screw, elliptical or drive hook.
ek	4	Locknuts
fn	1	Bracket, cutout extension.
Uae	1*	Surge arrester
Ugc	1	Cable riser shield. Length as required.
Ugk	1	Cable termination.
Uhc	1	Cable support.
Uhj	1	Bracket combination.

NOTES:

1. TOTAL ARRESTER LEAD LENGTH MUST BE UNDER 3'.
2. NO BENDS PERMITTED WITHIN 6" OF CABLE TERMINAL BASE.
3. ALLOW MINIMUM CABLE SLACK OF 24" AT BOTTOM OF RISER.

SINGLE PHASE CABLE DEADEND
TERMINAL POLE

2000

UA1

POSITION OF GUY

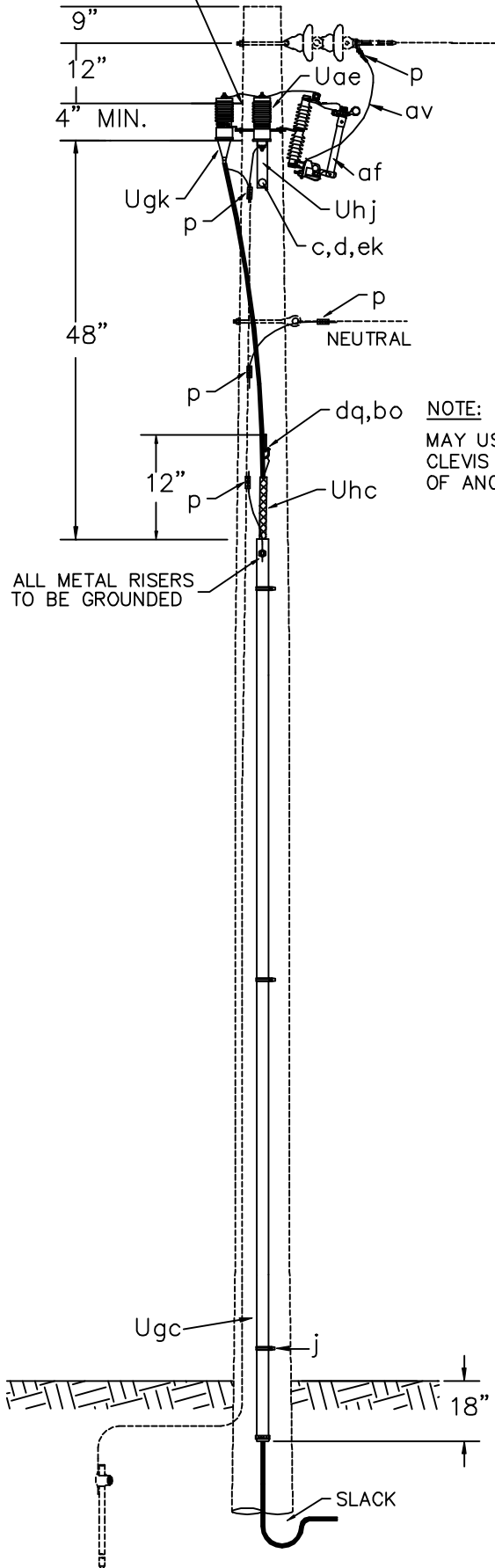

"B" MINIMUM	
7.2/12.5 kV	15"
14.4/24.9 kV	20"

NOTE:

MAY USE 2" SWINGING CLEVIS (ITEM s) INSTEAD OF ANCHOR SHACKLE.

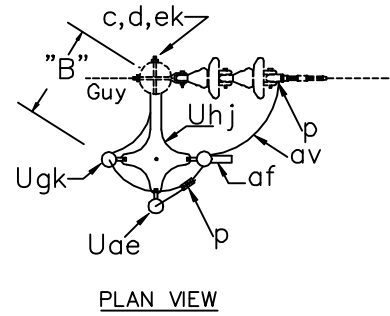

NOTES:

1. TOTAL ARRESTER LEAD LENGTH MUST BE UNDER 3'.
2. NO BENDS PERMITTED WITHIN 6" OF CABLE TERMINAL BASE.
3. ALLOW MINIMUM CABLE SLACK OF 24" AT BOTTOM OF RISER.

ITEM	QTY.	MATERIAL
c	2	Bolt, machine, 5/8" x required length.
d	2	Washer, square 2 1/4".
p		Connectors, as required.
j		Screw, lag, 1/2" x 4", as required.
af	1	Fuse link.
af	1	Cutout
av		Jumpers, as required.
bo	1	Anchor, shackle. Do not use if drive hook is used.
dq	1	Eye screw, elliptical or drive hook.
ek	2	Locknuts, as required.
Uae	1*	Surge arrester
Ugc		Cable Riser Shield, length as required
Ugk	1	Cable termination.
Uhc	1	Cable support.
Uhj	1	Equipment support bracket.

SINGLE PHASE CABLE DEADEND
TERMINAL POLE

2000

UA2

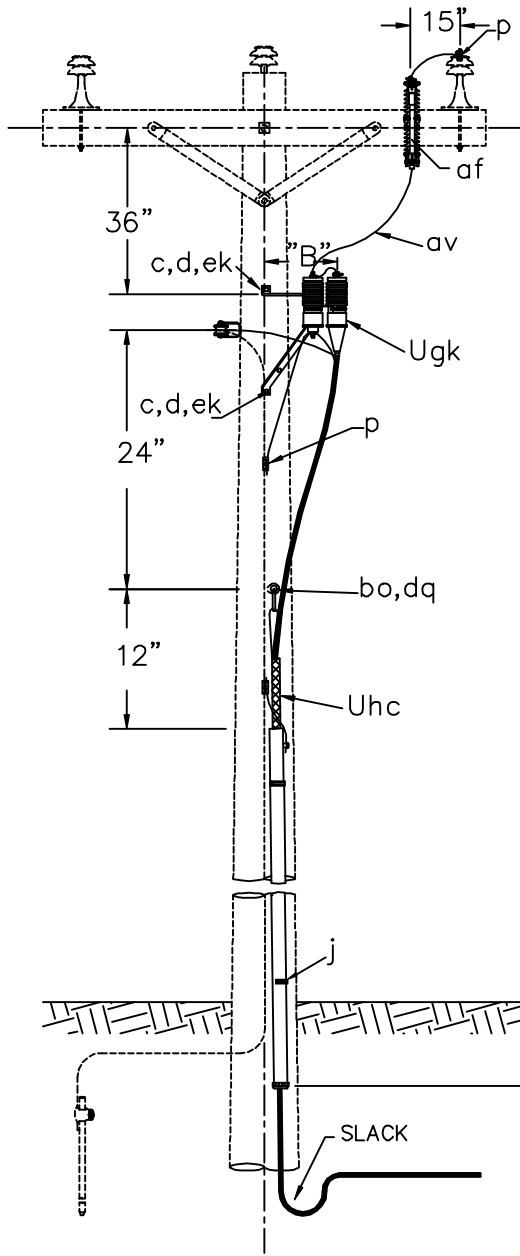

"B" MINIMUM	
7.2/12.5 kV	15"
14.4/24.9 kV	20"

ALL METAL RISERS
TO BE GROUNDED

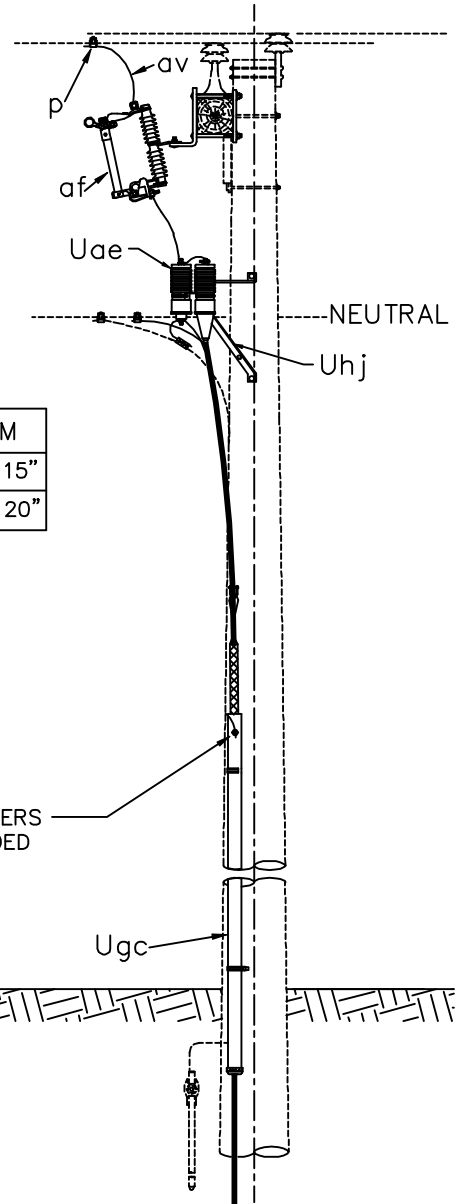

ITEM	QTY.	MATERIAL
c	2	Bolt, machine, 5/8" x required length.
d	2	Washer, square 2 1/4".
j		Screw, lag 1/2" x 4" as required.
p		Connectors, as required.
af	1	Fuse link.
af	1	Cutout
av		Jumpers, as required.
bo	1	Anchor, shackle. Do not use if drive hook is used.
dq	1	Eye screw, elliptical or drive hook.
ek	2	Locknuts
Uae	1*	Surge arrester
Ugc	1	Cable riser shield. Length as required.
Ugk	1	Cable termination.
Uhc	1	Cable support.
Uhj	1	Bracket combination.

NOTES:

1. TOTAL ARRESTER LEAD LENGTH MUST BE UNDER 3'.
2. NO BENDS PERMITTED WITHIN 6" OF CABLE TERMINAL BASE.
3. ALLOW MINIMUM CABLE SLACK OF 24" AT BOTTOM OF RISER.

SINGLE PHASE CABLE TANGENT
TERMINAL POLE

2000

UA3

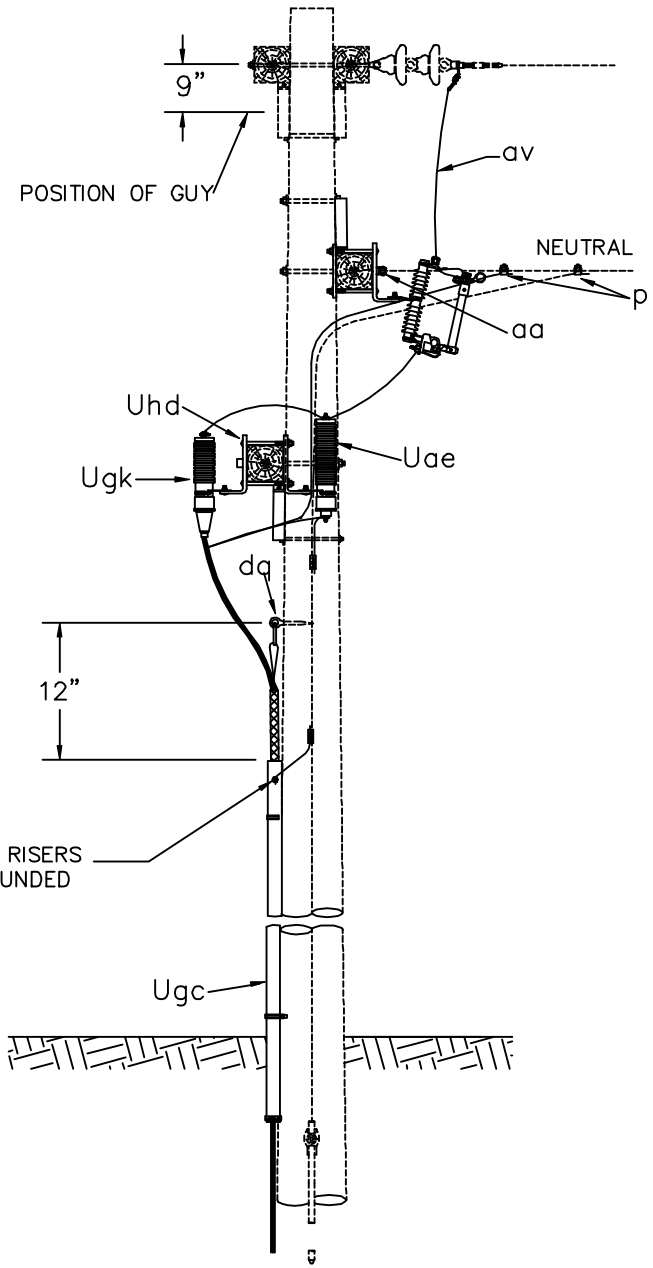
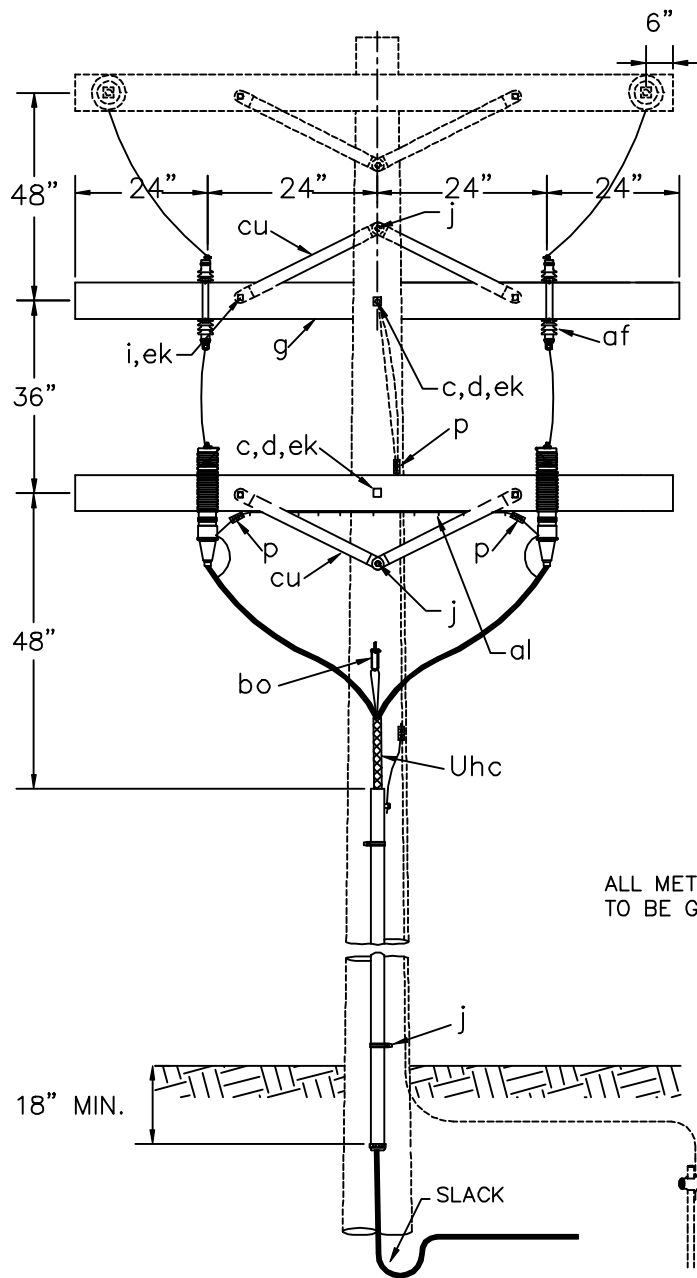

ITEM	QTY.	MATERIAL
c	2	Bolt, machine, 5/8" x required length.
d	2	Washer, square 2 1/4".
g	2	Crossarm, 3 5/8" x 4 5/8" x 8'-0"
i	4	Bolt, carriage, 3/8" x 4 1/2"
j		Screw, lag 1/2" x 4" as required.
p		Connectors, as required.
aa	1	Eyenuts, 5/8"
af	2	Cutout
al		Staples, as required.
av		Jumpers, as required.
bo	1	Anchor, shackle.
cu	4	Brace, wood, 28"
dq	1	Eye screw, elliptical or drive hook.
ek	6	Locknuts, as required.
Uae	2*	Surge arrester
Ugc	1	Cable riser shield. Length as required.
Ugk	2	Cable termination.
Uhc	2	Cable support.
Uhd	2	Crossarm mounting bracket.

NOTES:

1. TOTAL ARRESTER LEAD LENGTH MUST BE UNDER 3'.
2. NO BENDS PERMITTED WITHIN 6" OF CABLE TERMINAL BASE.
3. ALLOW MINIMUM CABLE SLACK OF 24" AT BOTTOM OF RISERS.

VEE-PHASE CABLE TERMINAL POLE WITH CUTOUTS AND CROSSARM MOUNTING ARRESTERS

2000

UB1

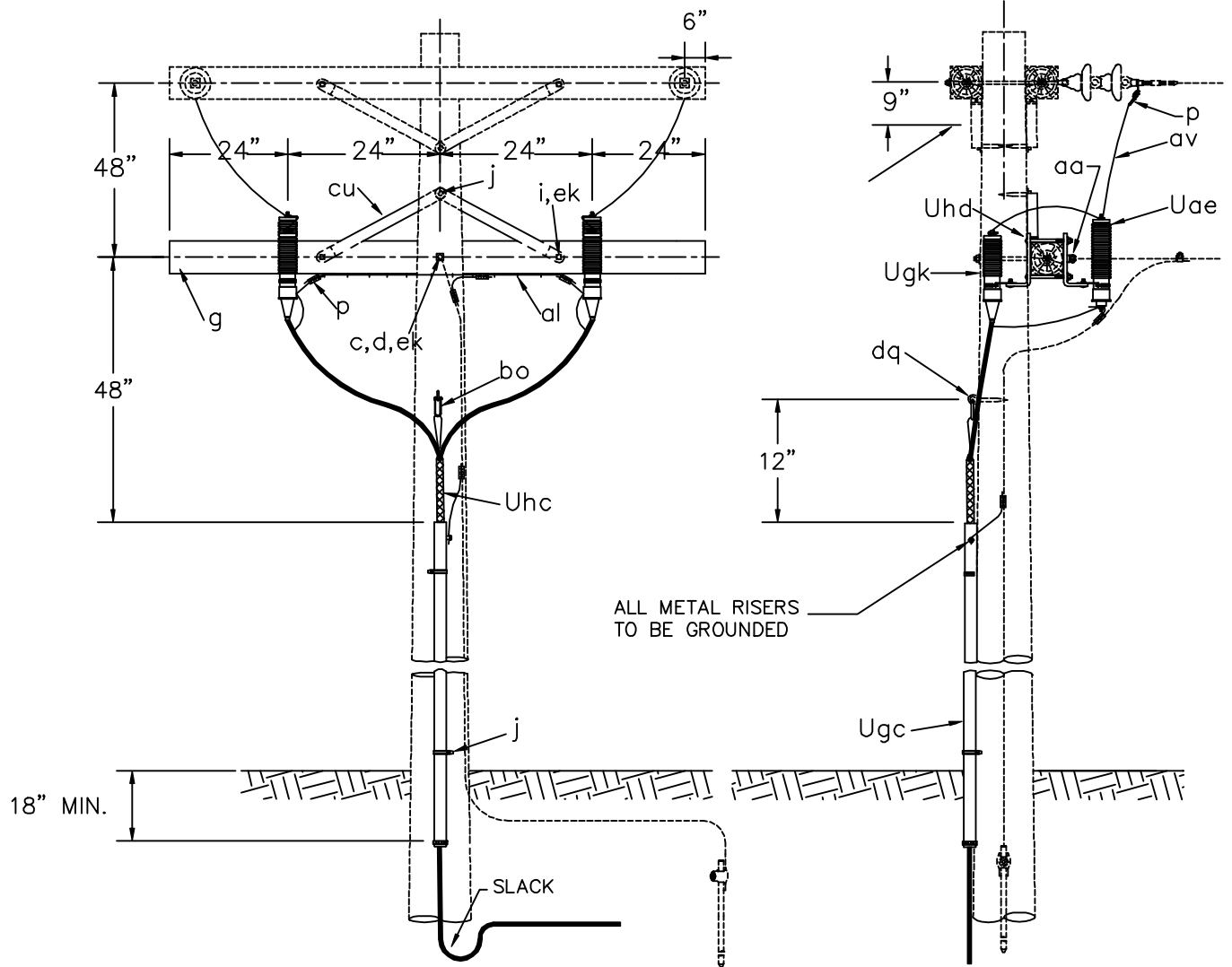

ITEM	QTY.	MATERIAL
c	1	Bolt, machine, 5/8" x required length.
d	1	Washer, square 2 1/4".
g	1	Crossarm, 3 5/8" x 4 5/8" x 8'-0"
i	2	Bolt, carriage, 3/8" x 4 1/2"
j		Screw, lag 1/2" x 4" as required.
p		Connectors, as required.
aa	1	Nut, eye, 5/8"
al		Staples, as required.
av		Jumpers, as required.
bo	1	Anchor, shackle.
cu	2	Brace, wood, 28"
dq	1	Eye screw, elliptical or drive hook.
ek	3	Locknuts, as required.
Uae	2*	Surge arrester
Ugc	1	Cable riser shield. Length as required.
Ugc	2	Cable termination.
Uhc	2	Cable support.
Uhd	2	Crossarm mounting bracket.

NOTES:

1. TOTAL ARRESTER LEAD LENGTH MUST BE UNDER 3'.
2. NO BENDS PERMITTED WITHIN 6" OF CABLE TERMINAL BASE.
3. ALLOW MINIMUM CABLE SLACK OF 24" AT BOTTOM OF RISER.

VEE-PHASE CABLE TERMINAL POLE WITHOUT CUTOUT, WITH CROSSARM MOUNTING ARRESTERS

2000

UB3

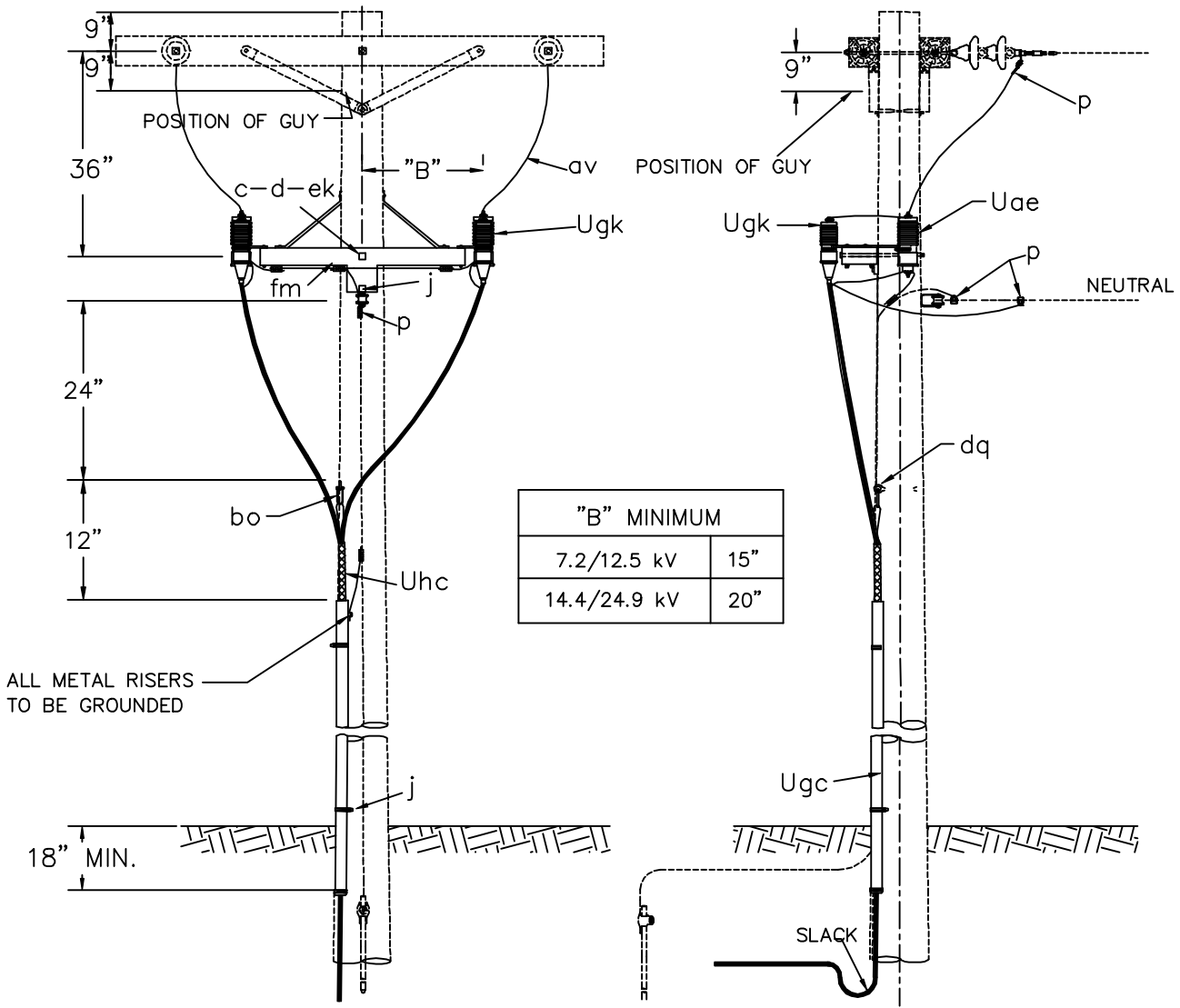

ITEM	QTY.	MATERIAL
c	1	Bolt, machine, 5/8" x required length.
d	1	Washer, square 2 1/4".
j		Screw, lag 1/2" x 4" as required.
p		Connectors, as required.
av		Jumpers, as required.
bo	1	Anchor, shackle.
dq	1	Eye screw, elliptical or drive hook.
ek		Locknuts, as required.
fm	1	Mounting bracket.
Uae	2*	Surge arrester
Ugc		Cable riser shield. Length as required.
Ugk	2	Cable termination.
Uhc	2	Cable support.

- NOTES:**
- TOTAL ARRESTER LEAD LENGTH MUST BE UNDER 3'.
 - NO BENDS PERMITTED WITHIN 6" OF CABLE TERMINAL BASE.
 - ALLOW MINIMUM CABLE SLACK OF 24" AT BOTTOM OF RISER.

VEE-PHASE CABLE TERMINAL POLE WITHOUT CUTOUT, WITH BRACKET MOUNTING ARRESTERS		
	2000	UB4

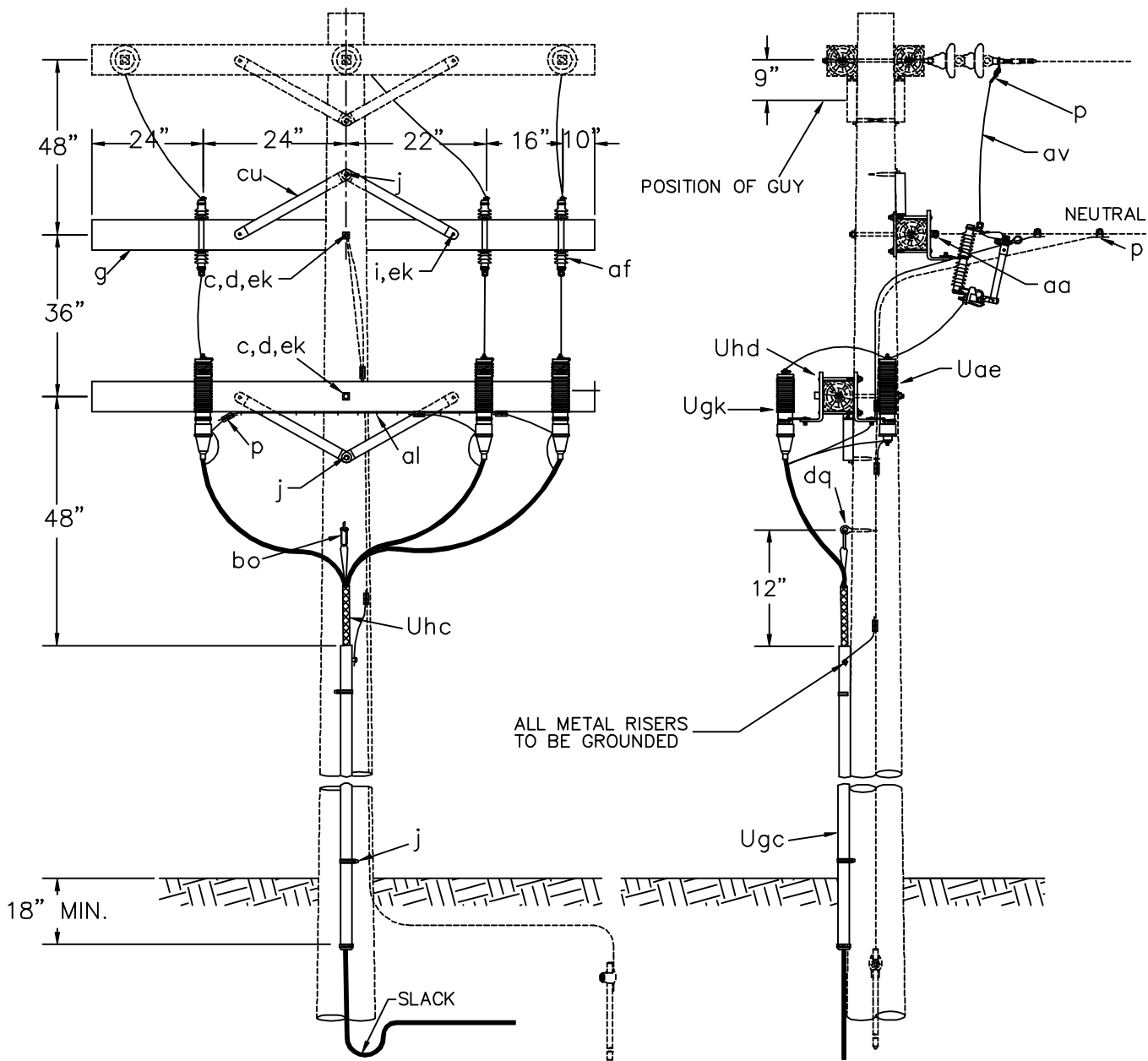

ITEM	QTY.	MATERIAL
c	2	Bolt, machine, 5/8" x required length.
d	2	Washer, square 2 1/4".
g	2	Crossarm, 3 5/8" x 4 5/8" x 8'-0"
i	4	Bolt, carriage, 3/8" x 4 1/2"
j		Screw, lag 1/2" x 4" as required.
p		Connectors, as required.
aa	1	Eyenut, 5/8"
af	3	Cutout
al		Staples, as required.
av		Jumpers, as required.
bo	1	Anchor, shackle.
cu	4	Brace, wood, 28"
dq	1	Eye screw, elliptical or drive hook.
ek	6	Locknuts, as required.
Uae	3*	Surge arrester
Ugc	1	Cable riser shield. Length as required.
Ugk	3	Cable termination.
Uhc	3	Cable support.
Uhd	2	Crossarm mounting bracket.

NOTES:

1. TOTAL ARRESTER LEAD LENGTH MUST BE UNDER 3'.
2. NO BENDS PERMITTED WITHIN 6" OF CABLE TERMINAL BASE.
3. ALLOW MINIMUM CABLE SLACK OF 24" AT BOTTOM OF RISER.

THREE PHASE CABLE TERMINAL POLE WITH CUTOUTS AND CROSSARM MOUNTING ARRESTERS

2000

UC1

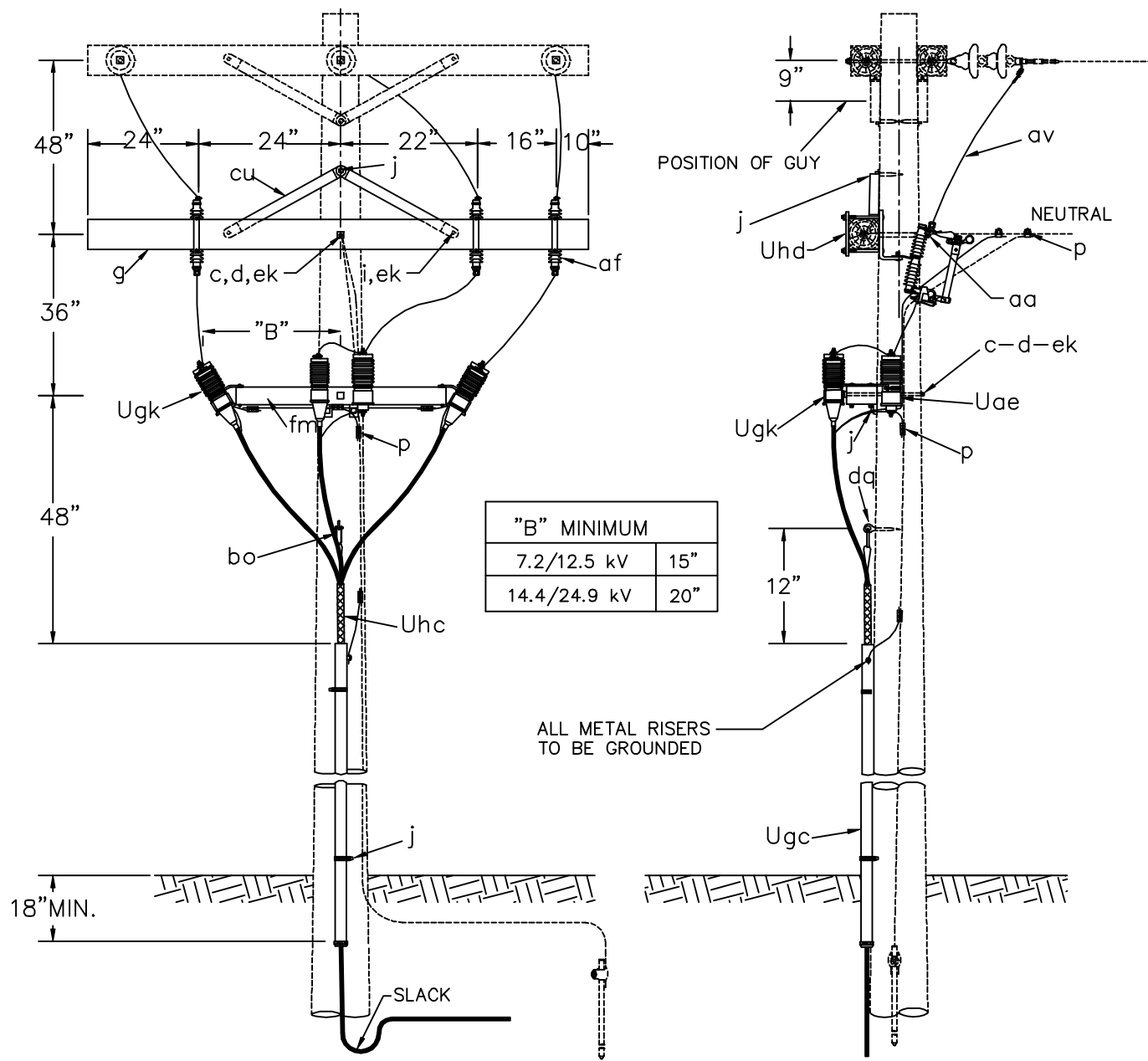

"B" MINIMUM	
7.2/12.5 kV	15"
14.4/24.9 kV	20"

ALL METAL RISERS TO BE GROUNDED

ITEM	QTY.	MATERIAL
c	2	Bolt, machine, 5/8" x required length.
d	2	Washer, square 2 1/4".
g	1	Crossarm, 3 5/8" x 4 5/8" x 8'-0"
i	2	Bolt, carriage, 3/8" x 4 1/2"
j		Screw, lag 1/2" x 4" as required.
p		Connectors, as required.
aa	1	Eyenuit, 5/8"
af	3	Cutout
av		Jumpers, as required.
bo	1	Anchor, shackle.
cu	2	Brace, wood, 28"
dq	1	Eye screw, elliptical or drive hook.
ek	4	Locknuts, as required.
fm	1	Mounting bracket.
Uae	3*	Surge arrester
Ugc	1	Cable riser shield. Length as required.
Ugk	3	Cable termination.
Uhc	3	Cable support.

NOTES:

- TOTAL ARRESTER LEAD LENGTH MUST BE UNDER 3'.
- NO BENDS PERMITTED WITHIN 6" OF CABLE TERMINAL BASE.
- ALLOW MINIMUM CABLE SLACK OF 24" AT BOTTOM OF RISER.

THREE PHASE CABLE TERMINAL POLE WITH CUTOUTS AND BRACKET MOUNTING ARRESTERS

2000 UC2

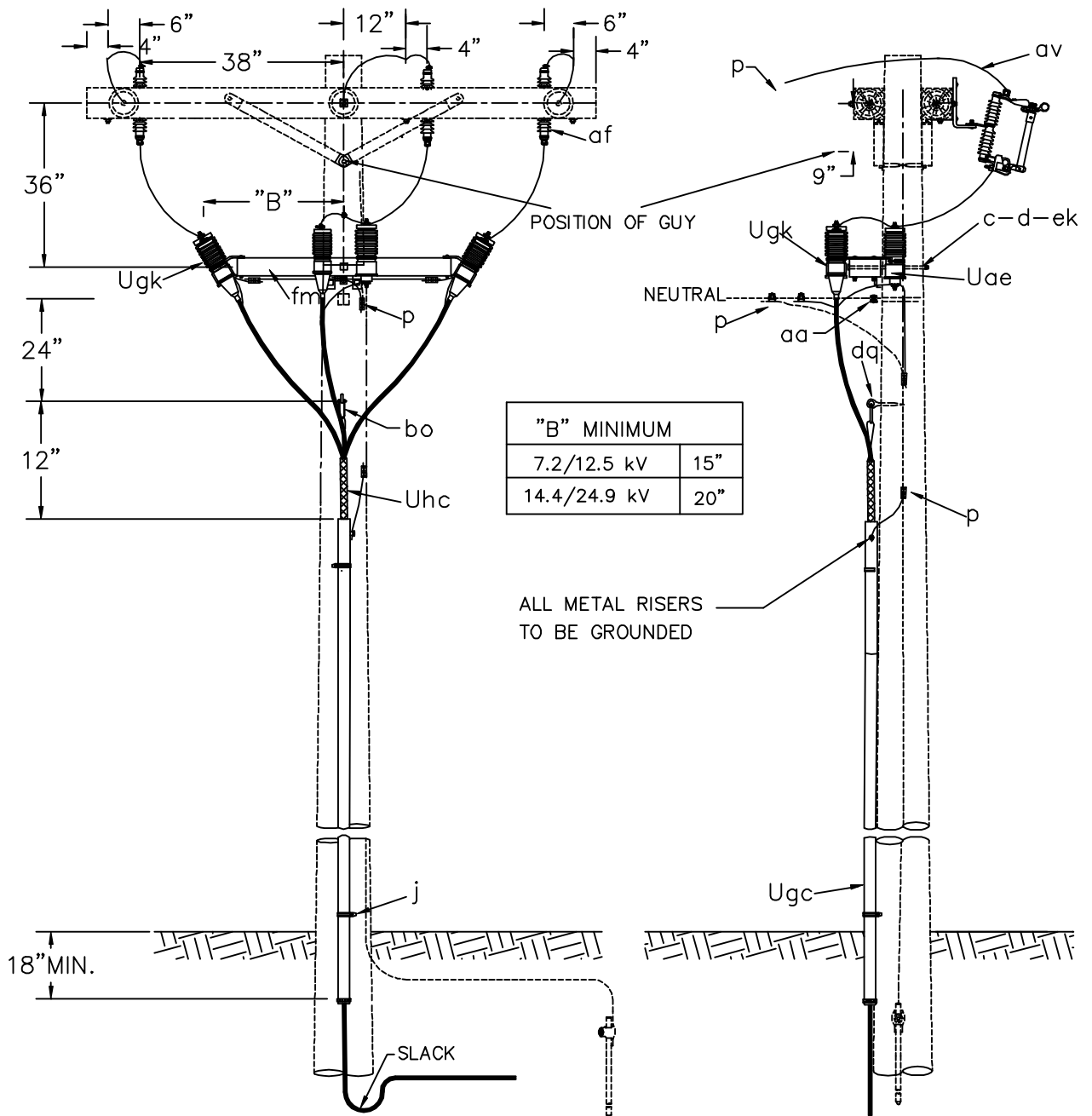

"B" MINIMUM	
7.2/12.5 kV	15"
14.4/24.9 kV	20"

ALL METAL RISERS TO BE GROUNDED

ITEM	QTY.	MATERIAL
a	3	Insulator, pin type
c	1	Bolt, machine, 5/8" x required length.
d	1	Washer, square 2 1/4".
f	3	Pin, crossarm
j		Screw, lag 1/2" x 4" as required.
p		Connectors, as required.
aa	1	Eyenuit, 5/8"
af	3	Cutout
av		Jumpers, as required.
bo	1	Anchor, shackle.
dq	1	Eye screw, elliptical or drive hook.
ek		Locknuts, as required.
fm	1	Mounting bracket.
Uae	3*	Surge arrester
Ugc	1	Cable riser shield. Length as required.
Ugk	3	Cable termination.
Uhc	3	Cable support.

NOTES:

1. TOTAL ARRESTER LEAD LENGTH MUST BE UNDER 3'.
2. NO BENDS PERMITTED WITHIN 6" OF CABLE TERMINAL BASE.
3. ALLOW MINIMUM CABLE SLACK OF 24" AT BOTTOM OF RISER.

THREE PHASE CABLE DEADEND
TERMINAL POLE

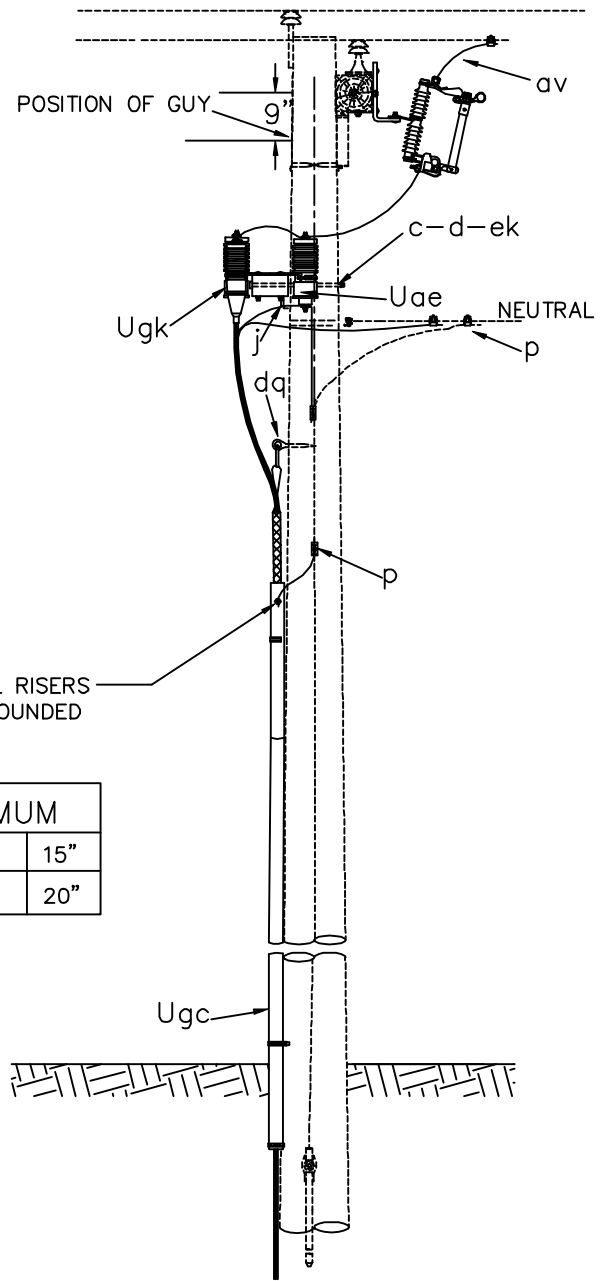
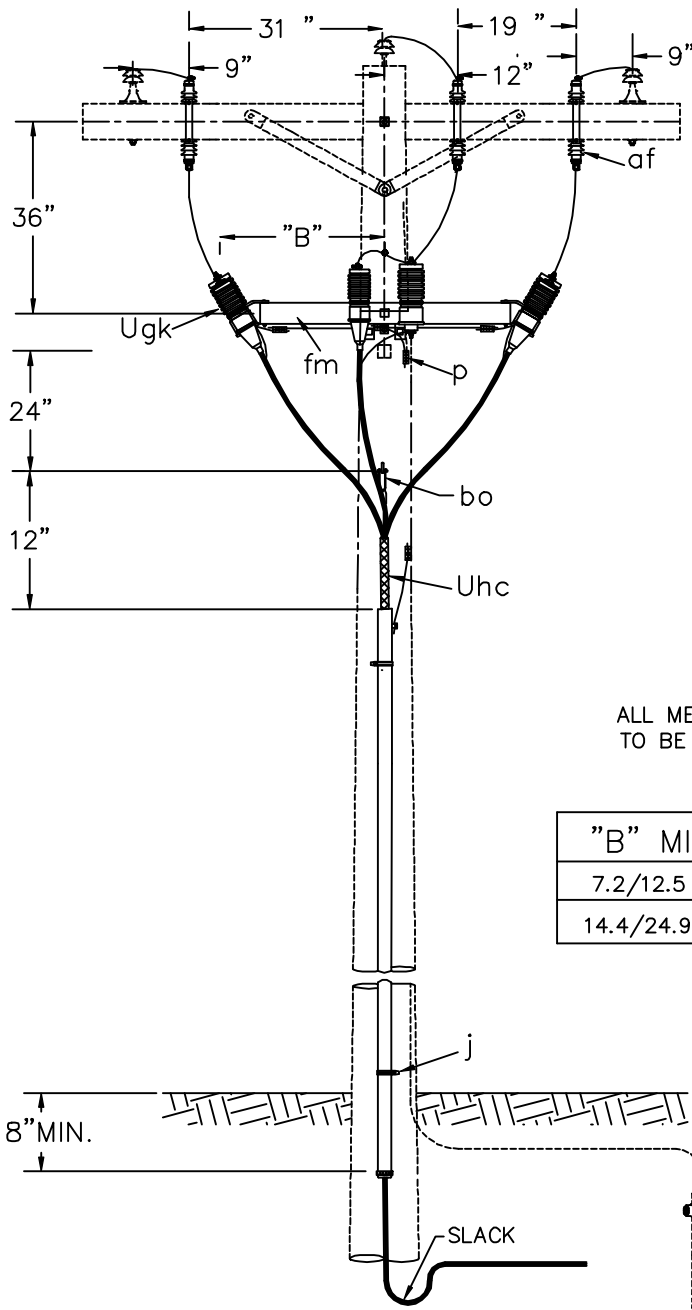

"B" MINIMUM	
7.2/12.5 kV	15"
14.4/24.9 kV	20"

18" MIN.

SLACK

ITEM	QTY.	MATERIAL
c	1	Bolt, machine, 5/8" x required length.
d	1	Washer, square 2 1/4".
j		Screw, lag 1/2" x 4" as required.
p		Connectors, as required.
aa	1	Eyenuit, 5/8"
af	3	Cutout
av		Jumpers, as required.
bo	1	Anchor, shackle.
dq	1	Eye screw, elliptical or drive hook.
ek		Locknuts, as required.
fm	1	Mounting bracket.
Uae	3*	Surge arrester
Ugc	1	Cable riser shield. Length as required.
Ugk	3	Cable termination.
Uhc	3	Cable support.

NOTES:

- TOTAL ARRESTER LEAD LENGTH MUST BE UNDER 3'.
- NO BENDS PERMITTED WITHIN 6" OF CABLE TERMINAL BASE.
- ALLOW MINIMUM CABLE SLACK OF 24" AT BOTTOM OF RISER.

THREE PHASE CABLE
TANGENT TERMINAL POLE

2000

UC2-2

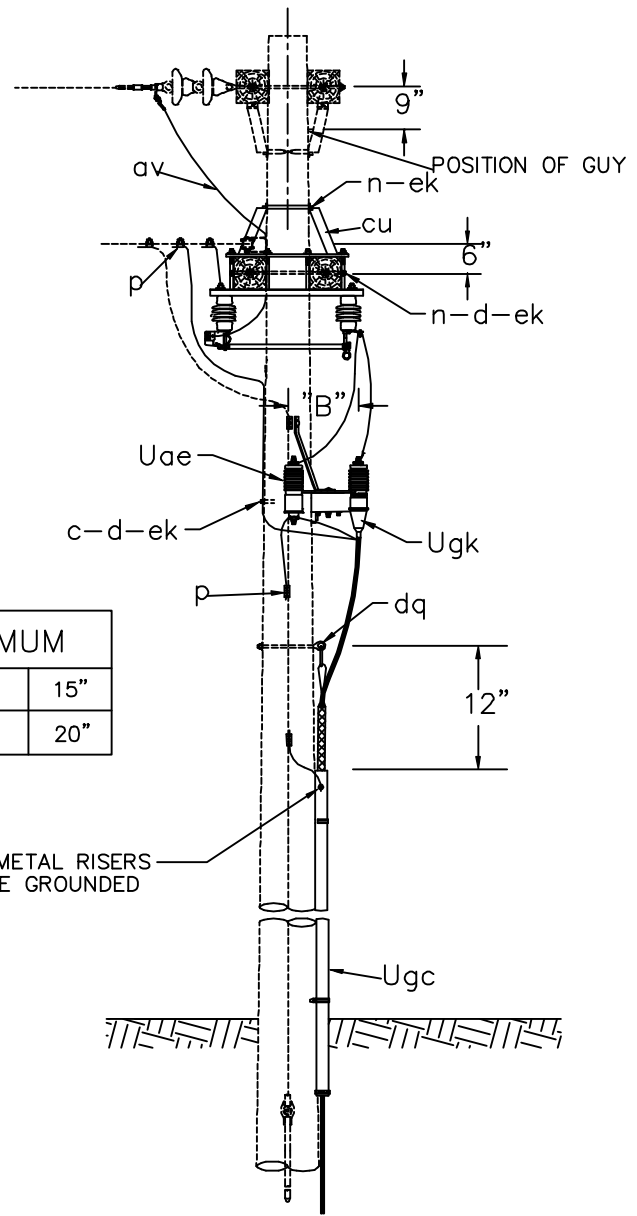
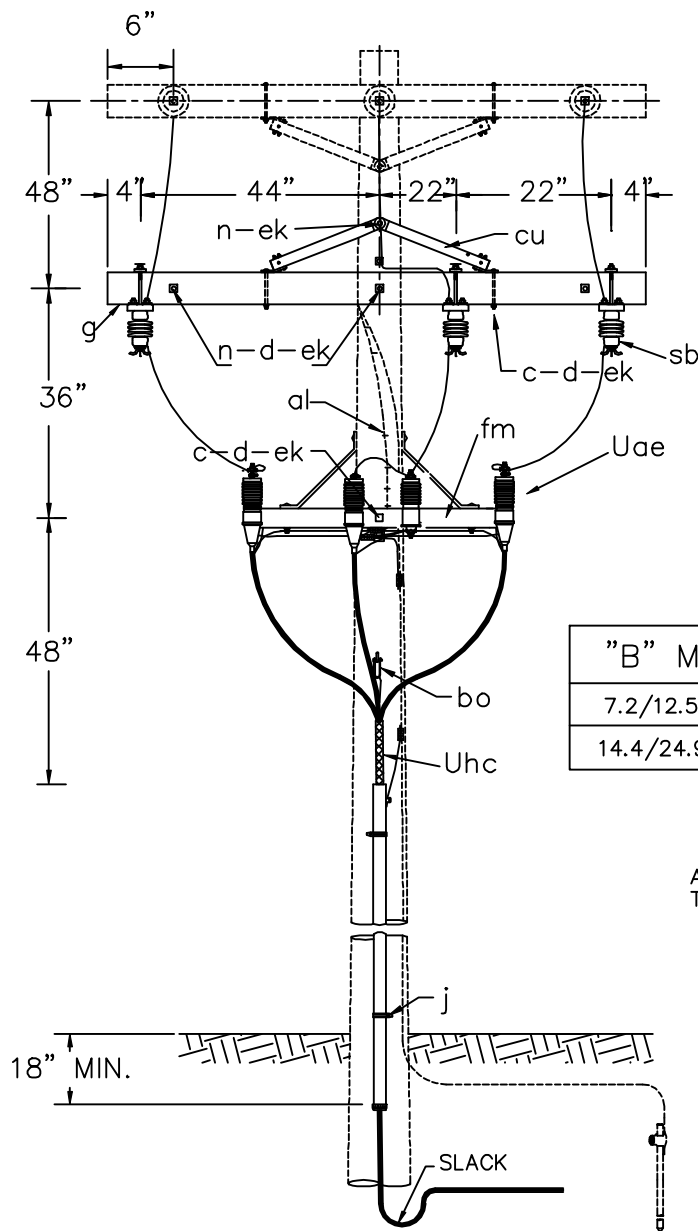

"B" MINIMUM	
7.2/12.5 kV	15"
14.4/24.9 kV	20"

ALL METAL RISERS TO BE GROUNDED

ITEM	QTY.	MATERIAL
c	5	Bolt, machine, 5/8" x as required
d	4	Washer, 1 3/8" x 9/16" round
d	12	Washer, 2 1/2" square
g	2	Crossarm, 3 5/8" x 4 5/8" x 8'-0"
j		Screw, lag 1/2" x 4", as required
n	4	Bolt, double arming, 5/8" x req'd length
p		Connectors, as required.
al		Staples, as required.
av		Jumpers, as required.
bo	1	Anchor, shackle.
cu	4	Brace, crossarm 60" span
dq	1	Eye screw, elliptical or drive hook.
ek	16	Locknuts, as required.
fm	1	Bracket, pothead-arrester 3 phase
sb	3	Disconnect, 600 A load break
Uae	3	Surge arrester
Ugc	1	Cable riser shield. Length as required.
Ugk	3	Cable termination.
Uhc	3	Grips

NOTES:

1. TOTAL ARRESTER LEAD LENGTH MUST BE UNDER 3'.
2. NO BENDS PERMITTED WITHIN 6" OF CABLE TERMINAL BASE.
3. ALLOW MINIMUM CABLE SLACK OF 24" AT BOTTOM OF RISER.

THREE PHASE CABLE DEADEND
TERMINAL POLE WITH
DISCONNECT SWITCHES

2000

UC5-1

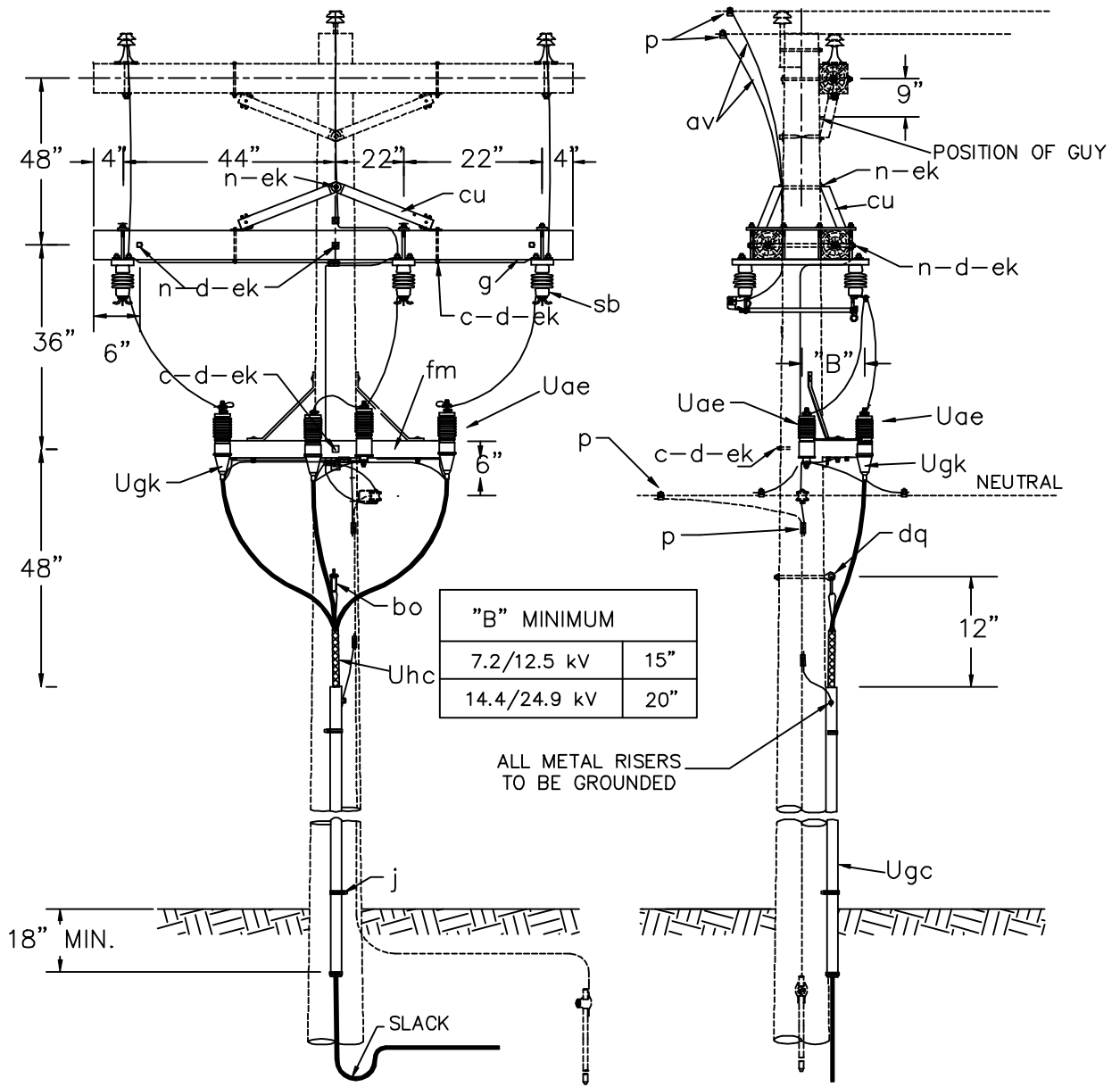

"B" MINIMUM	
7.2/12.5 kV	15"
14.4/24.9 kV	20"

ALL METAL RISERS TO BE GROUNDED

ITEM	QTY.	MATERIAL
c	4	Bolt, machine, 5/8" x as required
d	4	Washer, 1 3/8" x 9/16" round
d	12	Washer, 2 1/2" square
g	2	Crossarm, 3 5/8" x 4 5/8" x 8'-0"
j		Screw, lag 1/2" x 4", as required
n	4	Bolt, double arming, 5/8" x req'd length
p		Connectors, as required.
al		Staples, as required.
av		Jumpers, as required.
bo	1	Anchor, shackle.
cu	4	Brace, crossarm 60" span
dq	1	Eye screw, elliptical or drive hook.
ek		Locknuts, as required.
fm	1	Bracket, pothead-arrester 3 phase
sb	3	Disconnect, 600 A load break
Uae	3	Surge arrester
Ugc		Cable riser shield. Length as required.
Ugk	3	Cable termination.
Uhc	3	Grips

NOTES:

1. TOTAL ARRESTER LEAD LENGTH MUST BE UNDER 3'.
2. NO BENDS PERMITTED WITHIN 6" OF CABLE TERMINAL BASE.
3. ALLOW MINIMUM CABLE SLACK OF 24" AT BOTTOM OF RISER.

THREE PHASE CABLE TANGENT TERMINAL POLE WITH DISCONNECT SWITCHES		
	2000	UC6-1

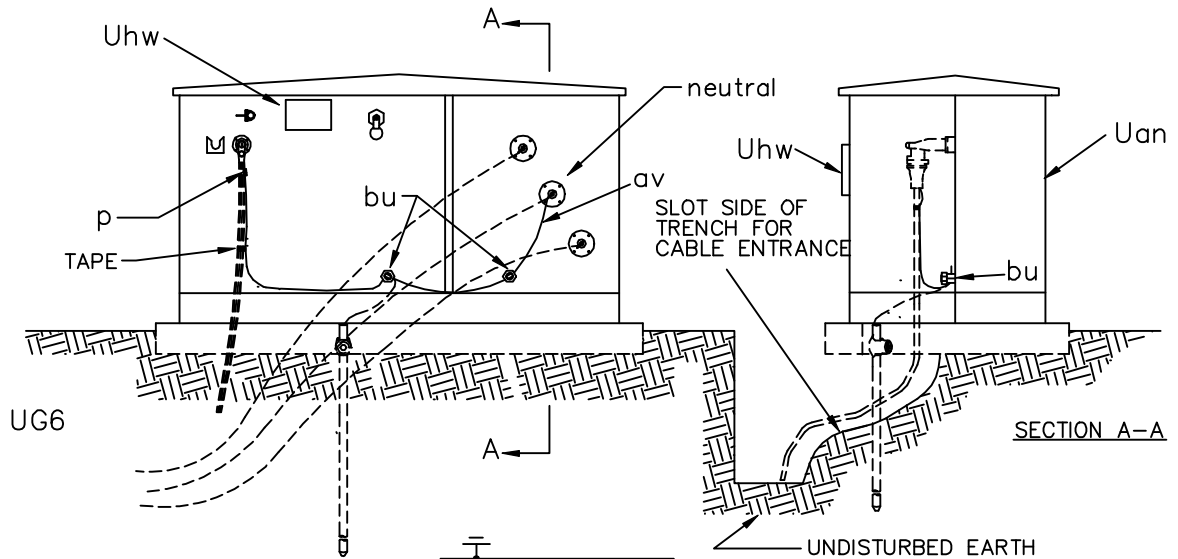

WIRING DIAGRAM
UG6

DESIGNATE AS:

TRANSFORMER WITHOUT SECONDARY BREAKERS	TRANSFORMER WITH SECONDARY BREAKERS	
UG6	UG6B	SINGLE TERMINATION TYPE WITH INTERNAL FUSE

ITEM	QTY.	MATERIAL
p		Connectors, as required
av		Jumpers, copper as required
bu	2	Connector, equipment ground
Uan	1	Transformer, pad mounted, single primary load break bushing and internal fuse (UG6 & UG6B).
Uhw	2	Signs, "DANGER" and "WARNING"
		Tape, as required

NOTES:

1. PROVIDE SUFFICIENT PRIMARY NEUTRAL PIGTAIL AND CABLE SLACK TO PERMIT READY DISCONNECTION OF ELBOW AND MOUNTING ON PARKING STAND. TRAIN CABLES AS SHOWN.
2. INSTALL WITH UNIT UM48-1 OR OTHER GROUNDING UNIT TO BE SPECIFIED SEPARATELY.
3. SPECIFY PAD OR SLEEVE SEPARATELY.
4. INSTALL "DANGER" SIGN ON TRANSFORMER INSIDE ENCLOSURE. INSTALL "WARNING" SIGN ON OUTSIDE SURFACE OF ENCLOSURE.

SINGLE PHASE
PAD-MOUNTED TRANSFORMER
(RADIAL FEED)

2000

UG6,
UG6B

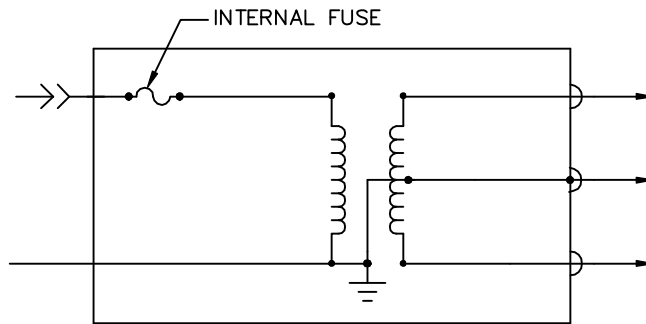
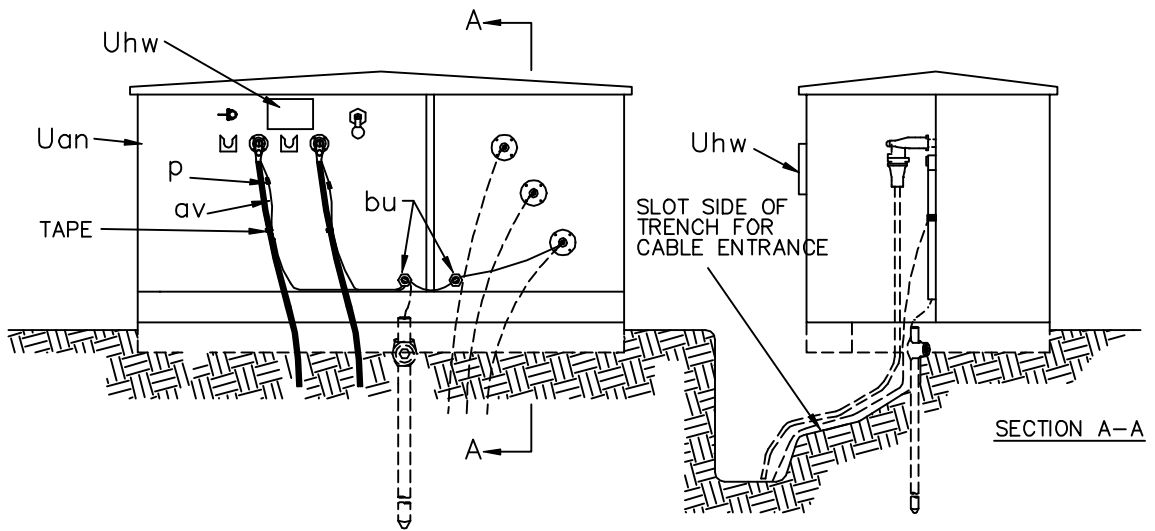

WIRING DIAGRAM
UG7

DESIGNATE AS:

TRANSFORMER WITHOUT SECONDARY BREAKERS	TRANSFORMER WITH SECONDARY BREAKERS	
UG7	UG17B	UNIT WITH INTERNAL FUSE

ITEM	QTY.	MATERIAL
p		Connectors, as required
av		Jumpers, copper as required
bu	2	Connector, equipment ground
Uan	1	Transformer, pad mounted, single phase with one load break bushing per phase and internal fuses (UG7 & UG17B)
Uhw	2	Signs, "DANGER" and "WARNING"
Uhp	1	Elbow Termination
		Ground wire (See Note #3)
		Tape, as required

NOTES:

1. PROVIDE SUFFICIENT PRIMARY NEUTRAL PIGTAIL AND CABLE SLACK TO PERMIT READY DISCONNECTION OF ELBOW AND MOUNTING ON PARKING STAND. TRAIN CABLES AS SHOWN.
2. INSTALL WITH UNIT UM48-1 OR OTHER GROUNDING UNIT TO BE SPECIFIED SEPARATELY.
3. SPECIFY PAD OR SLEEVE UNIT SEPARATELY.
4. INSTALL "DANGER" SIGN ON TRANSFORMER AND "WARNING" SIGN ON ENCLOSURE.

SINGLE PHASE
PAD MOUNTED TRANSFORMER
(LOOP FEED)

2000

UG7
UG7B

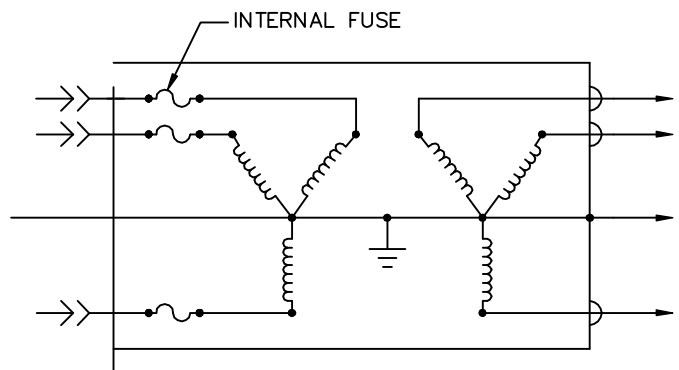
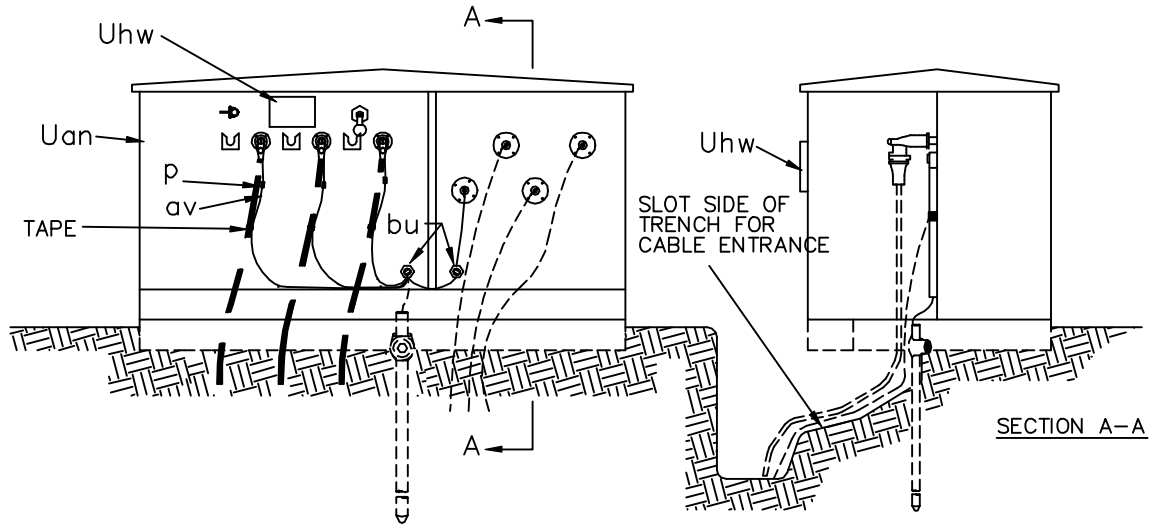

DESIGNATE AS:

WIRING DIAGRAM
UG 17

TRANSFORMER WITHOUT SECONDARY BREAKERS	TRANSFORMER WITH SECONDARY BREAKERS	
UG17	UG17B	UNIT WITH INTERNAL FUSE

NOTES:

- ONLY THE WYE-WYE CONNECTION SHOULD BE USED TO MINIMIZE FERRO-RESONANCE.
- PROVIDE SUFFICIENT PRIMARY NEUTRAL PIGTAIL AND CABLE SLACK TO PERMIT READY DISCONNECTION OF ELBOW AND MOUNTING ON PARKING STAND. TRAIN CABLES AS SHOWN.
- INSTALL WITH UNIT UM48-1 OR OTHER GROUNDING UNIT TO BE SPECIFIED SEPARATELY.
- SPECIFY PAD OR SLEEVE UNIT SEPARATELY.
- INSTALL "DANGER" SIGN ON TRANSFORMER INSIDE ENCLOSURE. INSTALL "WARNING" SIGN ON OUTSIDE SURFACE OF ENCLOSURE.
- THREE PHASE SWITCHING OF PRIMARY SHOULD BE INSTALLED WHERE FERRORESONANCE MAY OCCUR.

ITEM	QTY.	MATERIAL
p		Connectors, as required
av		Jumpers, copper as required
bu	2	Connector, equipment ground
Uan	1	Transformer, pad mounted, three phase with one load break bushing per phase and internal fuses (UG17 & UG17B)
Uhw	2	Signs, "DANGER" and "WARNING"
Uhp	3	Elbow Termination
		Ground wire (See Note #3)
		Tape, as required

THREE PHASE PAD MOUNTED TRANSFORMER (RADIAL FEED)		
	2000	UG17 UG17B

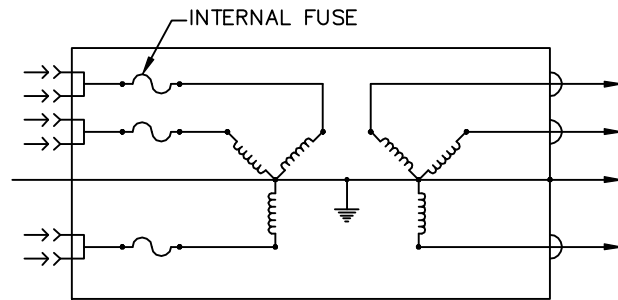
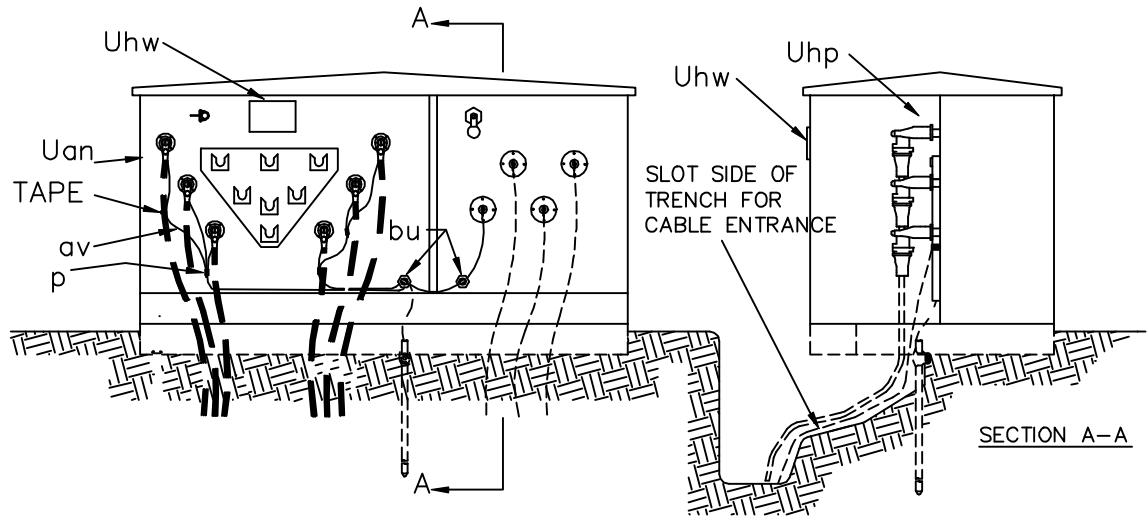

WIRING DIAGRAM
UG17-2

DESIGNATE AS:

TRANSFORMER WITHOUT SECONDARY BREAKERS	TRANSFORMER WITH SECONDARY BREAKERS	
UG17-2	UG17-2B	UNIT WITH INTERNAL FUSE

NOTES:

- ONLY THE WYE-WYE CONNECTION SHOULD BE USED TO AVOID FERRORESONANCE.
- PROVIDE SUFFICIENT PRIMARY NEUTRAL PIGTAIL AND CABLE SLACK TO PERMIT READY DISCONNECTION OF ELBOW AND MOUNTING ON PARKING STAND. TRAIN CABLES AS SHOWN.
- INSTALL WITH GROUNDING ASSEMBLY TO BE SPECIFIED.
- SPECIFY kVA SIZE OF TRANSFORMER.
- SPECIFY PAD OR SLEEVE UNIT SEPARATELY.
- INSTALL "DANGER" SIGN ON TRANSFORMER INSIDE ENCLOSURE. INSTALL "WARNING" SIGN ON OUTSIDE SURFACE OF ENCLOSURE.

ITEM	QTY.	MATERIAL
p		Connectors, as required
av		Jumpers, copper, as required
bu	2	Connector, equipment ground
Uan	1	Transformer, pad mounted, three phase with two load break bushings per phase and internal fuse.
Uhv	2	Signs, "DANGER" and "WARNING"
Uhp	6	Elbow termination
		Tape, as required
		Ground wire (See Note #3)

THREE PHASE
PAD MOUNTED TRANSFORMER
(LOOP FEED)

2000

UG17-2
UG17-2B

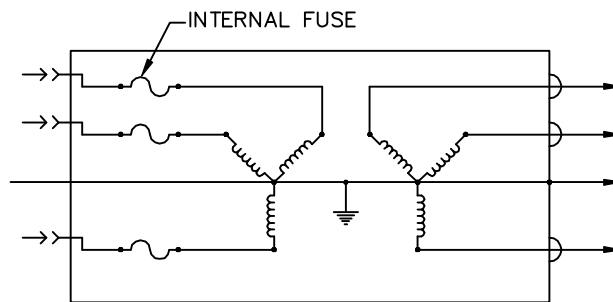
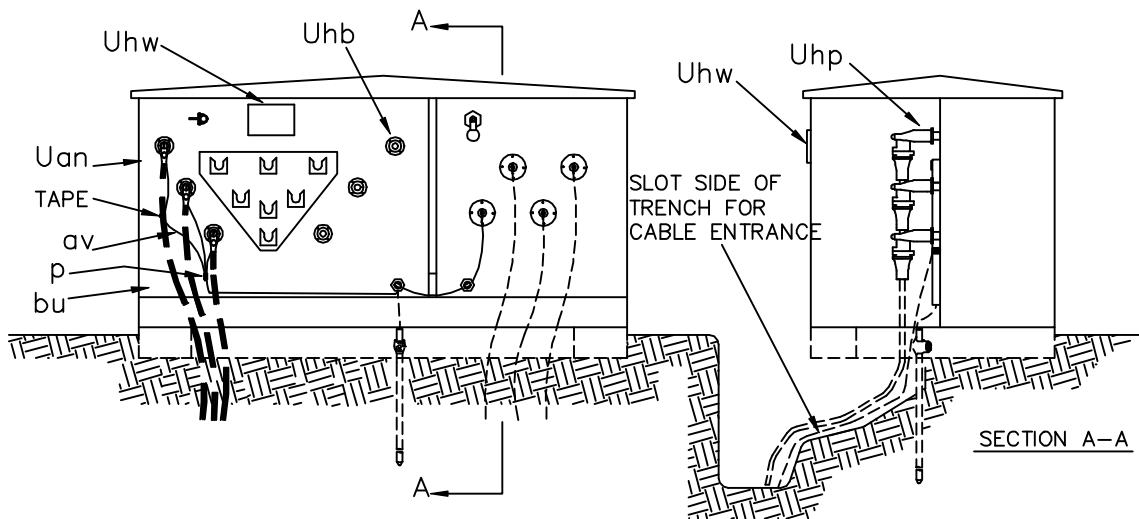

WIRING DIAGRAM

DESIGNATE AS:

TRANSFORMER WITHOUT SECONDARY BREAKERS	TRANSFORMER WITH SECONDARY BREAKERS	
UG17-3	UG17-3B	UNIT WITH INTERNAL FUSE

NOTES:

1. ONLY THE WYE-WYE CONNECTION SHOULD BE USED TO AVOID FERRORESONANCE.
2. PROVIDE SUFFICIENT PRIMARY NEUTRAL PIGTAIL AND CABLE SLACK TO PERMIT READY DISCONNECTION OF ELBOW AND MOUNTING ON PARKING STAND. TRAIN CABLES AS SHOWN.
3. INSTALL WITH GROUNDING ASSEMBLY TO BE SPECIFIED SEPARATELY.
4. SPECIFY PAD OR SLEEVE UNIT SEPARATELY.
5. INSTALL "DANGER" SIGN ON TRANSFORMER INSIDE ENCLOSURE. INSTALL "WARNING" SIGN ON OUTSIDE SURFACE OF ENCLOSURE.

ITEM	QTY.	MATERIAL
p		Connectors, as required
av		Jumpers, copper, as required
bu	2	Connector, equipment ground
Uan	1	Transformer, pad mounted, three phase, with two load break bushings per phase and internal fuse.
Uhb	3	Insulated covers
Uhw	2	Signs, "DANGER" and "WARNING"
Uhp	3	Elbow termination
		Tape, as required
		Ground wire (See Note #3)

THREE PHASE PAD MOUNTED LOOP FEED TRANSFORMER WITH RADIAL FEED	
2000	UG17-3 UG17-3B

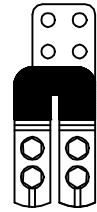

UJ1-2

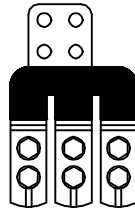

UJ1-3

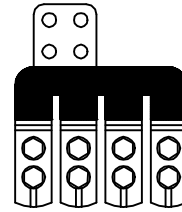

UJ1-4

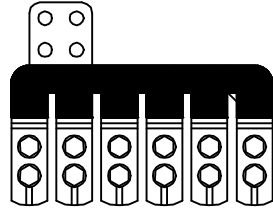

UJ1-6

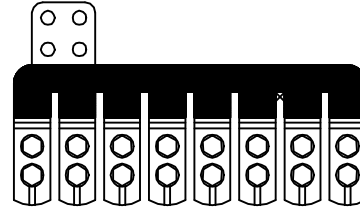

UJ1-8

CONNECTOR BLOCKS

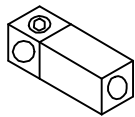

UJ2-1

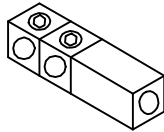

UJ2-2

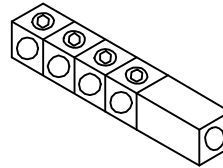

UJ2-4

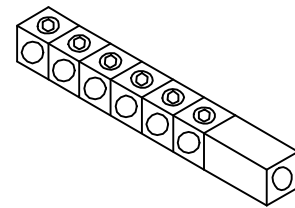

UJ2-6

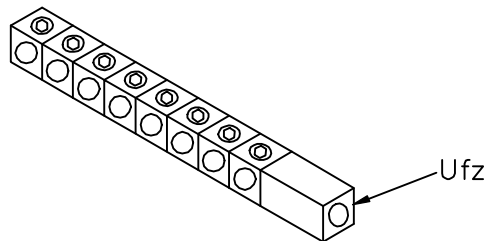

UJ2-8

TRANSFORMER CONNECTOR BLOCKS

NOTE: Insulated covers are not shown.

ITEM	QTY.	MATERIAL	SECONDARY CONNECTOR BLOCKS	
Ufz		Transformer connector blocks, as required	2000	UJ1-__
Ugp		Connector blocks, as required		UJ2-__

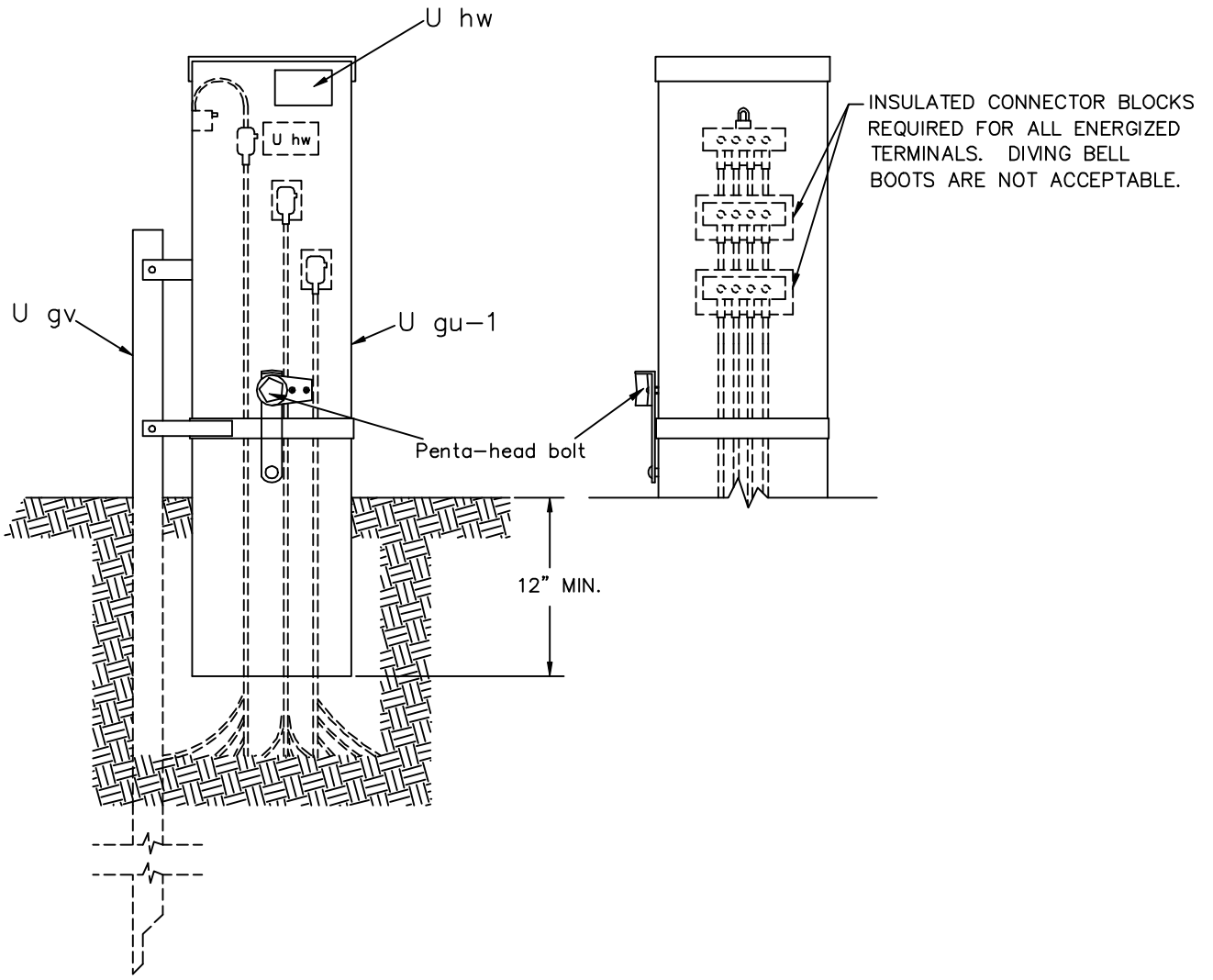

NOTES:

1. INSTALL "WARNING" SIGN ON OUTSIDE OF PEDESTAL.
2. ITEM Ugv OPTIONAL – SEE PEDESTAL MANUFACTURER'S SPECIFICATIONS AND RECOMMENDATIONS.
3. ALL PEDESTALS SHALL BE GROUNDED IN ACCORDANCE WITH THE NATIONAL ELECTRICAL SAFETY CODE (NESC).

ITEM	QTY.	MATERIAL		
Ugw-1	1	Power pedestal	SECONDARY PEDESTAL UNDERGROUND CABLE	
Ugv	1	Stake (if necessary)		
Uhw	1	Sign, "WARNING" (outside pedestal)	2000	
Uhw	1	Sign, "DANGER" (inside pedestal)		

INSULATED SUBMERSIBLE CONNECTOR BLOCKS
 REQUIRED FOR ALL TERMINALS.
 DIVING BELL BOOTS ARE NOT ACCEPTABLE.

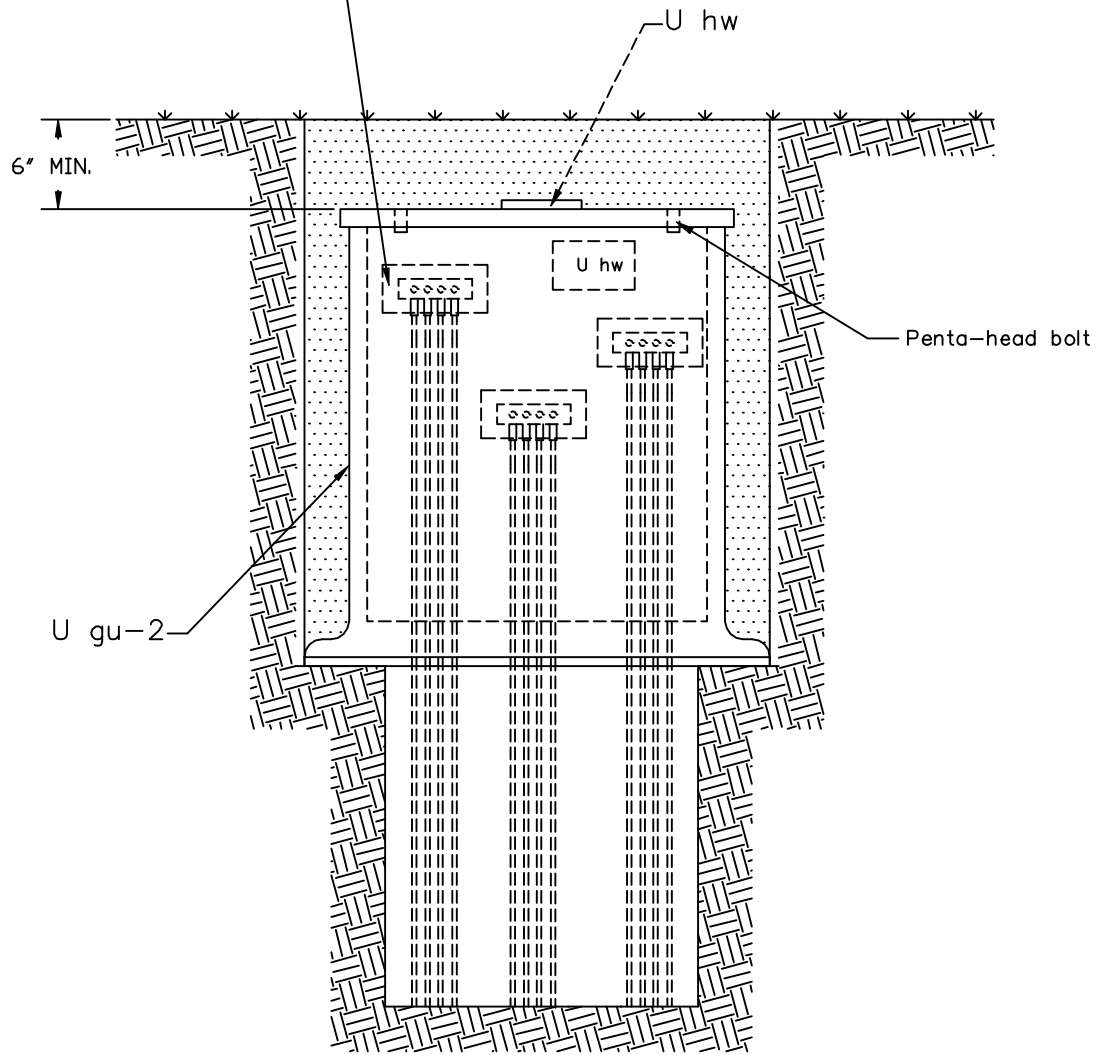

NOTES:

1. OWNER TO SPECIFY WHETHER UNIT IS TO BE BURIED AS SHOWN OR INSTALLED FLUSH WITH FINAL GRADE. METAL COVER IF USED SHOULD BE GROUNDED.
2. ALL PEDESTALS SHALL BE GROUNDED IN ACCORDANCE WITH THE NATIONAL ELECTRICAL SAFETY CODE (NEC).

ITEM	QTY.	MATERIAL			
U gu-2	1	Power pedestal, buried type	SECONDARY HANDHOLE UNDERGROUND CABLE		
U hw	1	Sign, "DANGER" (inside pedestal)			
U hw	1	Sign, "WARNING" (outside pedestal)			
			2000	UK6	

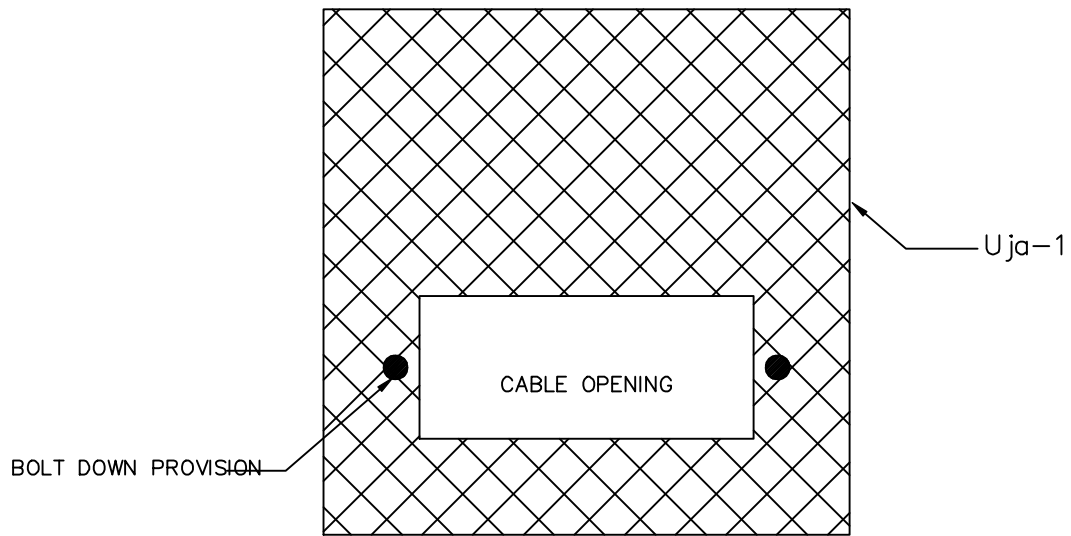

NOTES:

1. PAD ASSEMBLIES INCLUDE SITE PREPARATION, BEDDING AND DRAINAGE.
2. EQUIPMENT SHALL BE SECURED TO PAD IN ACCORDANCE WITH MANUFACTURERS INSTRUCTIONS.
3. CABLE OPENING AND PAD DIMENSIONS SHALL BE AS REQUIRED.

UNIT DESIGNATION:

UM1-5C	CONCRETE
UM1-5NC	NON-CONCRETE

	PAD ASSEMBLIES		
	2000	UM1-5C UM1-5NC	

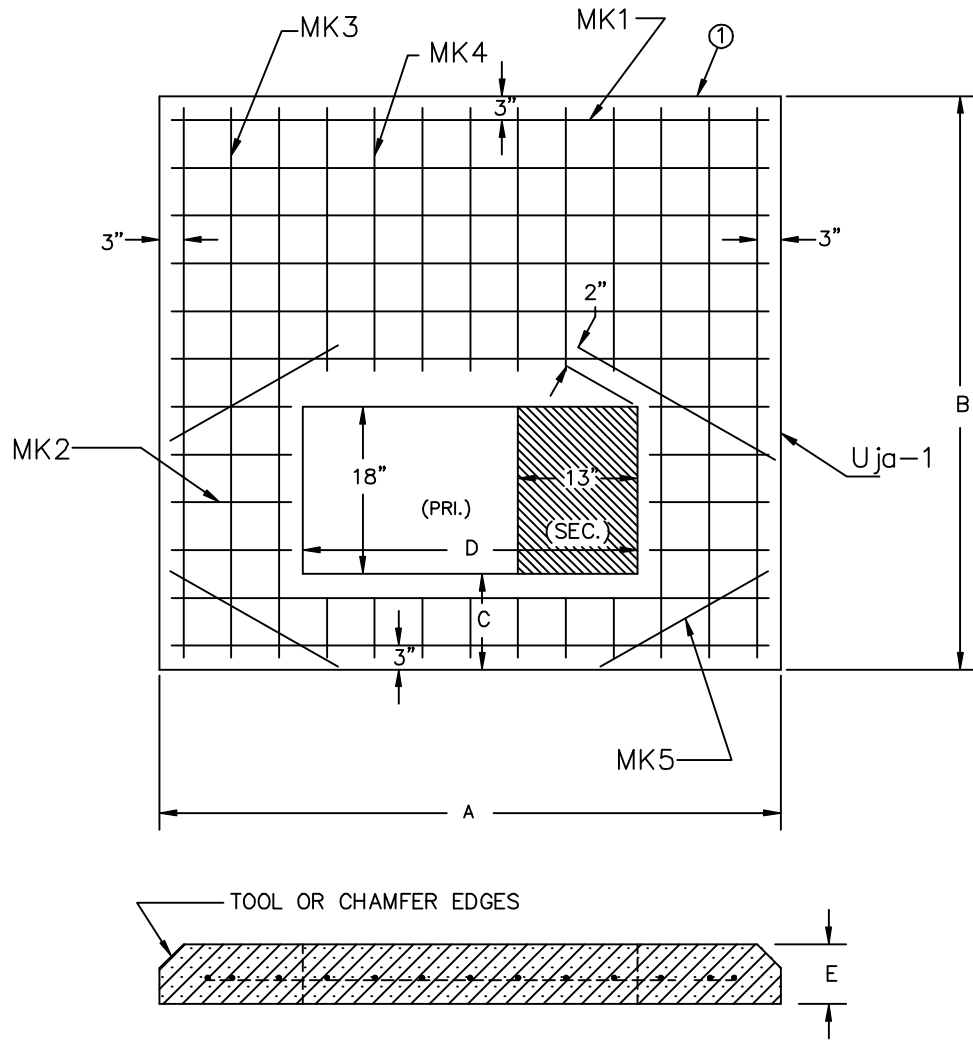

PAD	3-PHASE TRANSF. kVA	DIMENSIONS IN INCHES					REINFORCING BARS				
		A	B	C	D	E	MK1	MK2	MK3	MK4	MK5
#1	75, 112 1/2, 150, 225, 300, 500	76	62	10	42	6	7 #4 70"	4 #4 10"	6 #4 57"	6 #4 28"	4 #4 26"
#2	750, 1000 1500, 2500	104	100	10	54	8	12 #4 98"	6 #4 19"	6 #4 94"	7 #4 66"	4 #4 29"

NOTES:

1. CONCRETE TESTING, 3000 POUNDS MIN. PER SQUARE INCH; 4% TO 6% ENTRAINED AIR, 3/4" MAXIMUM SIZE AGGREGATE.
2. REINFORCING STEEL, ATSM-A615 GRADE 60, PLACE APPROX. 6" O.C. EACH WAY AND SECURELY TIED TOGETHER.
3. MINIMUM CONCRETE COVER OVER REINFORCING STEEL 2 INCHES UNLESS NOTED.
4. WOOD FLOAT FINISH, LEAVING NO DEPRESSIONS.

THREE PHASE TRANSFORMER CONCRETE PADS	
2000	UM1-6C

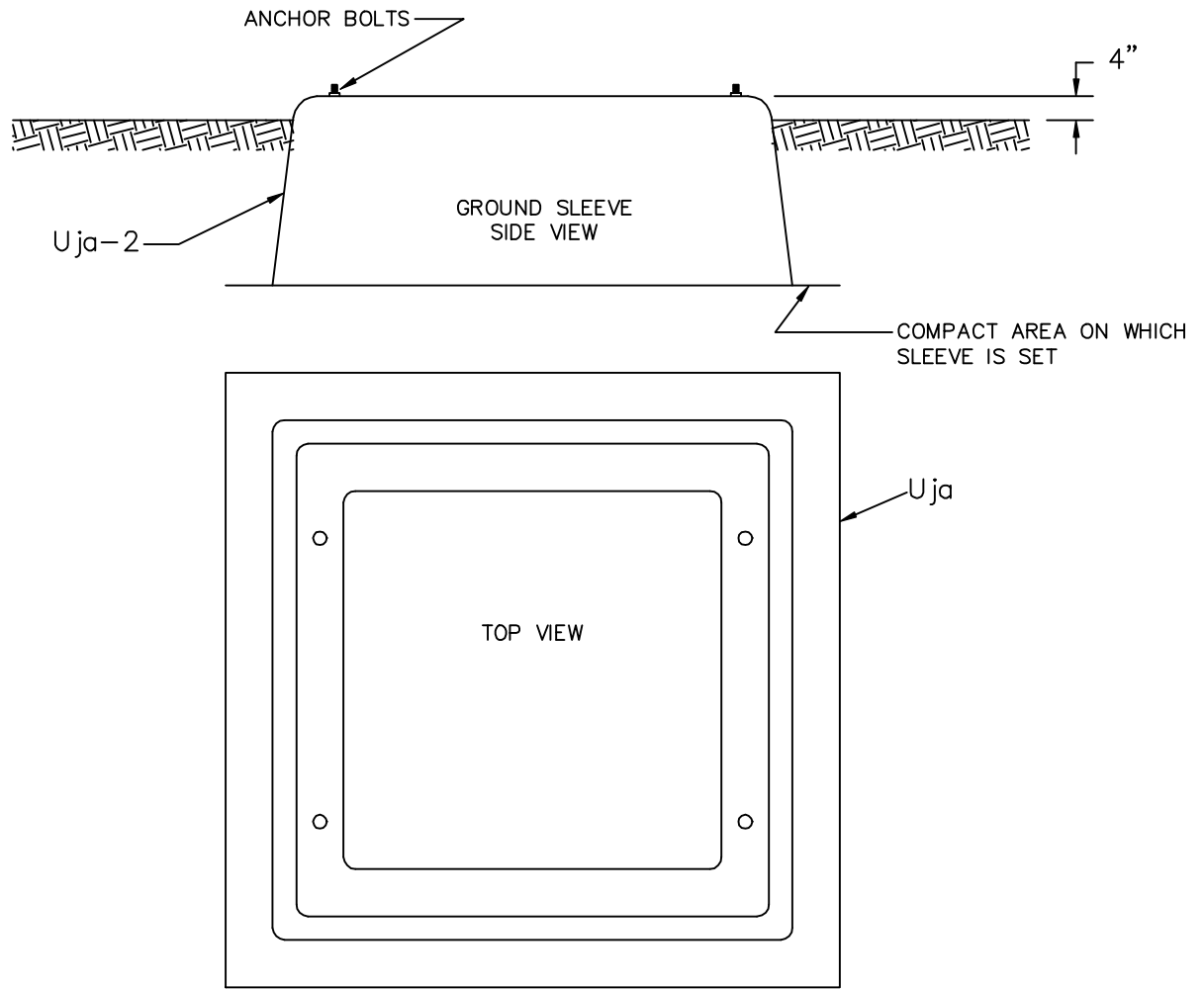

UNIT DESIGNATIONS:

UM1-7C CONCRETE

UM1-7NC NON-CONCRETE

		GROUND SLEEVE ASSEMBLY	
		2000	UM1-7C UM1-7NC

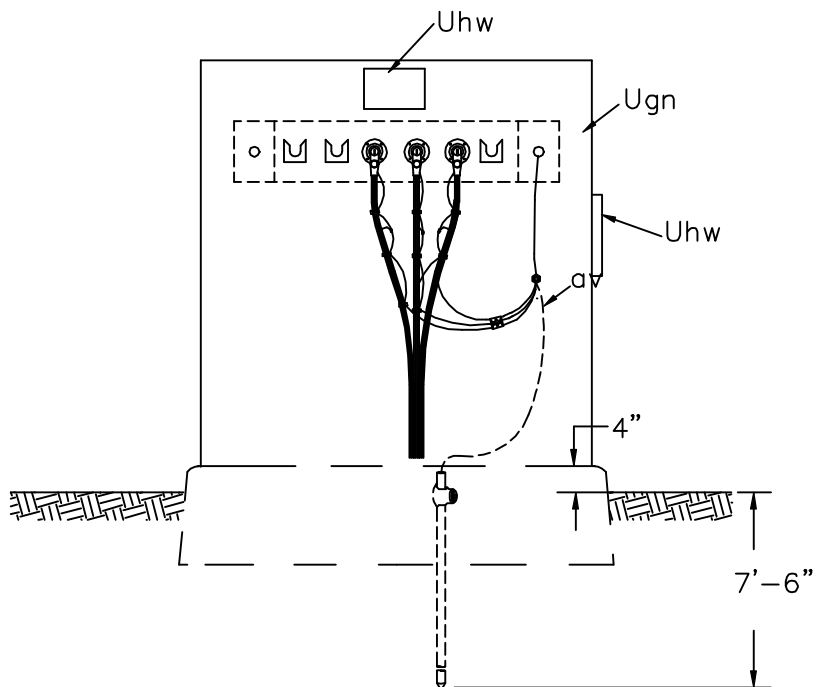

NOTE:

1. THE FOLLOWING UNITS/ASSEMBLIES ARE NOT PART OF THIS UNIT. SPECIFY SEPARATELY:
 - A. MULTIPPOINT TERMINATION AND OTHER ACCESSORIES
 - B. FUSED OR NON-FUSED LOADBREAK ELBOWS
 - C. GROUNDING ASSEMBLY UM48-1 OR OTHER
 - D. PAD OR SLEEVE (IF REQUIRED)

2. INSTALL "WARNING" SIGN ON OUTSIDE SURFACE OF ENCLOSURE AND "DANGER" SIGN INSIDE ENCLOSURE.

3. PROVIDE SUFFICIENT PRIMARY NEUTRAL PIGTAIL AND CABLE SLACK TO PERMIT READY DISCONNECTION OF ELBOW AND MOUNTING ON PARKING STAND.

ITEM	QTY.	MATERIAL
p		Connectors, as required
av		Jumpers, as required
Ugn	1	Enclosure
Uhw	2	Signs, "DANGER" and "WARNING"
Ugc		Cable riser shield, length as required

		SINGLE PHASE SECTIONALIZING ENCLOSURE	
		2000	UM3-14

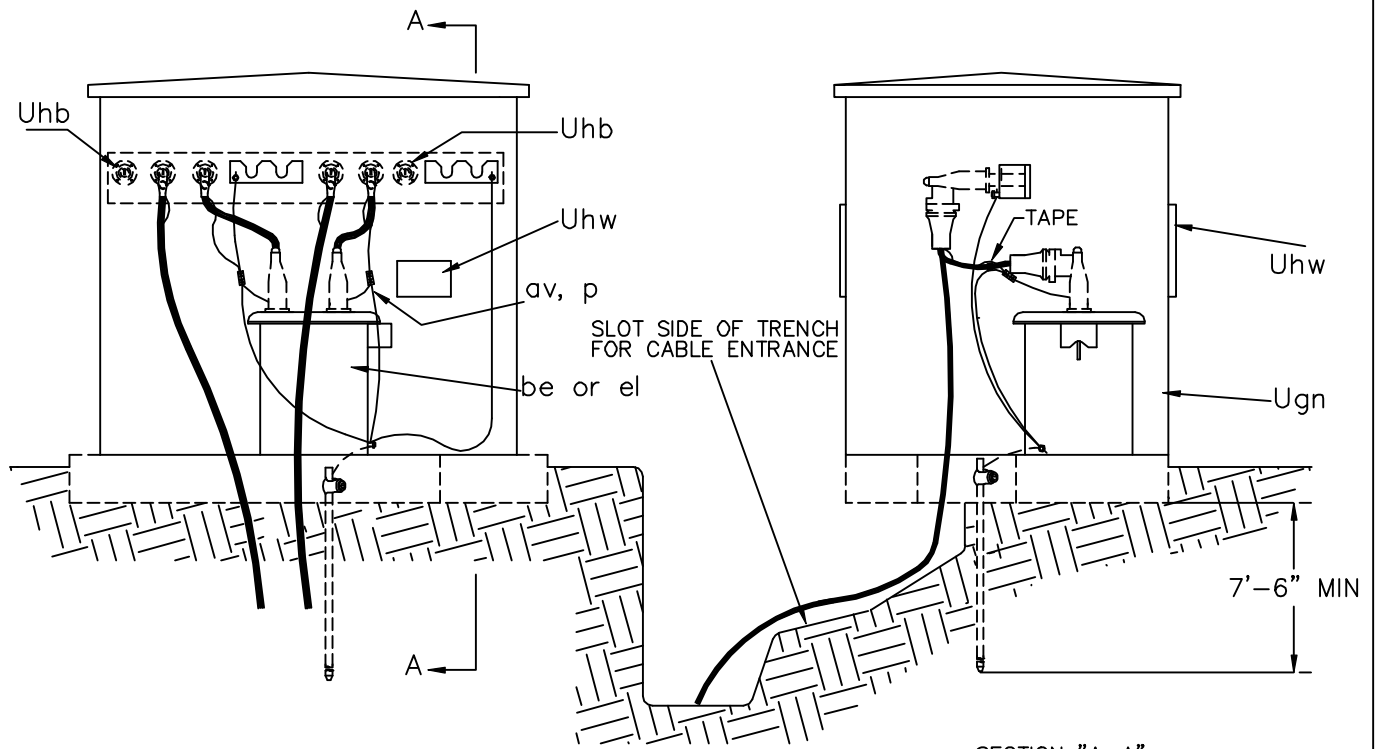

DESIGNATE AS:

RECLOSER ASSEMBLY UM3-44

SECTIONALIZER ASSEMBLY UM3-45

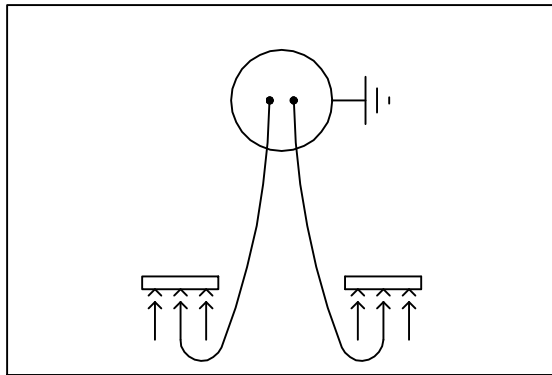

WIRING DIAGRAM

NOTES:

1. THE FOLLOWING UNITS/ASSEMBLIES ARE NOT PART OF THIS UNIT. SPECIFY SEPARATELY:
 - A. MULTIPoint TERMINATIONS AND OTHER ACCESSORIES
 - B. LOADBREAK ELBOWS
 - C. GROUNDING ASSEMBLY UM48-1 OR OTHER
 - D. PAD ASSEMBLY
2. PROVIDE SUFFICIENT SLACK IN ALL CABLES TO PERMIT READY DISCONNECTION OF ELBOW AND MOUNTING ON PARKING STAND.
3. ANCHOR RECLOSER AND ENCLOSURE TO PAD.
4. INSTALL "WARNING" SIGN OUTSIDE SURFACE OF ENCLOSURE AND "DANGER" SIGN INSIDE ENCLOSURE.

ITEM	QTY.	MATERIAL
p		Connectors, as required
av		Jumpers, as required
be	1	Recloser, oil circuit with bushing wells (UM3-44).
el	1	Sectionalizer, with bushing wells (UM3-45).
Ugn	1	Enclosure
Uhb	2	Insulated covers
Uhw	2	Signs, "DANGER" and "WARNING"

SINGLE PHASE PAD MOUNTED
SECTIONALIZER OR RECLOSER

2000

UM3-44
UM3-45

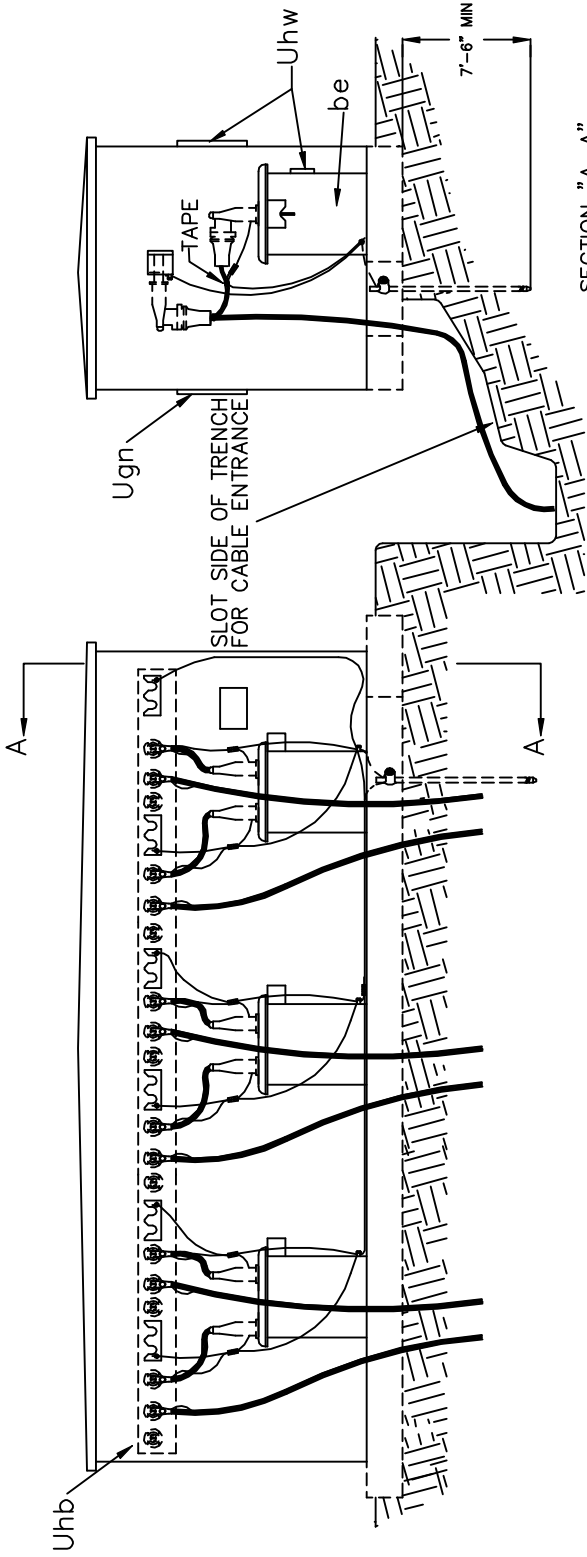

SECTION "A-A"

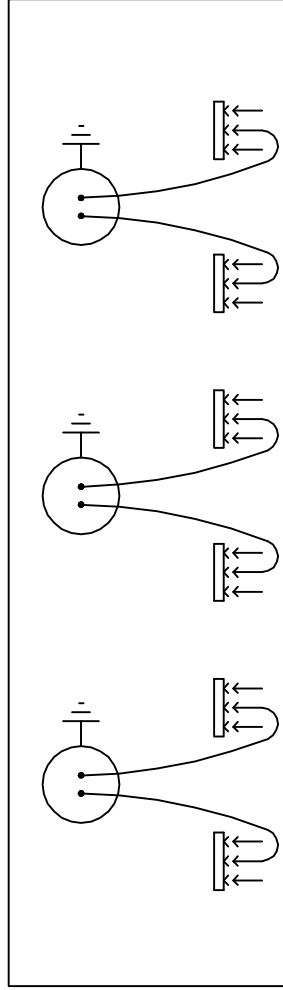

WIRING DIAGRAM

NOTES:

1. THE FOLLOWING UNITS/ASSEMBLIES ARE NOT PART OF THIS UNIT. SPECIFY SEPARATELY:
 - A. MULTIPoint TERMINATIONS AND OTHER ACCESSORIES
 - B. LOADBREAK ELBOWS
 - C. GROUNDING ASSEMBLY UM48-1 OR OTHER
 - D. PAD ASSEMBLY
2. PROVIDE SUFFICIENT SLACK IN ALL CABLES TO PERMIT READY DISCONNECTION OF ELBOW AND MOUNTING ON PARKING STAND.
3. ANCHOR RECLOSER AND ENCLOSURE TO PAD.
4. INSTALL "WARNING" SIGN OUTSIDE SURFACE OF ENCLOSURE AND "DANGER" SIGN INSIDE ENCLOSURE.

ITEM	QTY.	MATERIAL
be	3	Recloser, oil circuit with bushing wells
Ugn	1	Enclosure
Uhbw	6	Insulated covers
Uhw	2	Signs, "DANGER" and "WARNING"

THREE, SINGLE PHASE
PAD MOUNTED RECLOSERS

2000

UM3-46

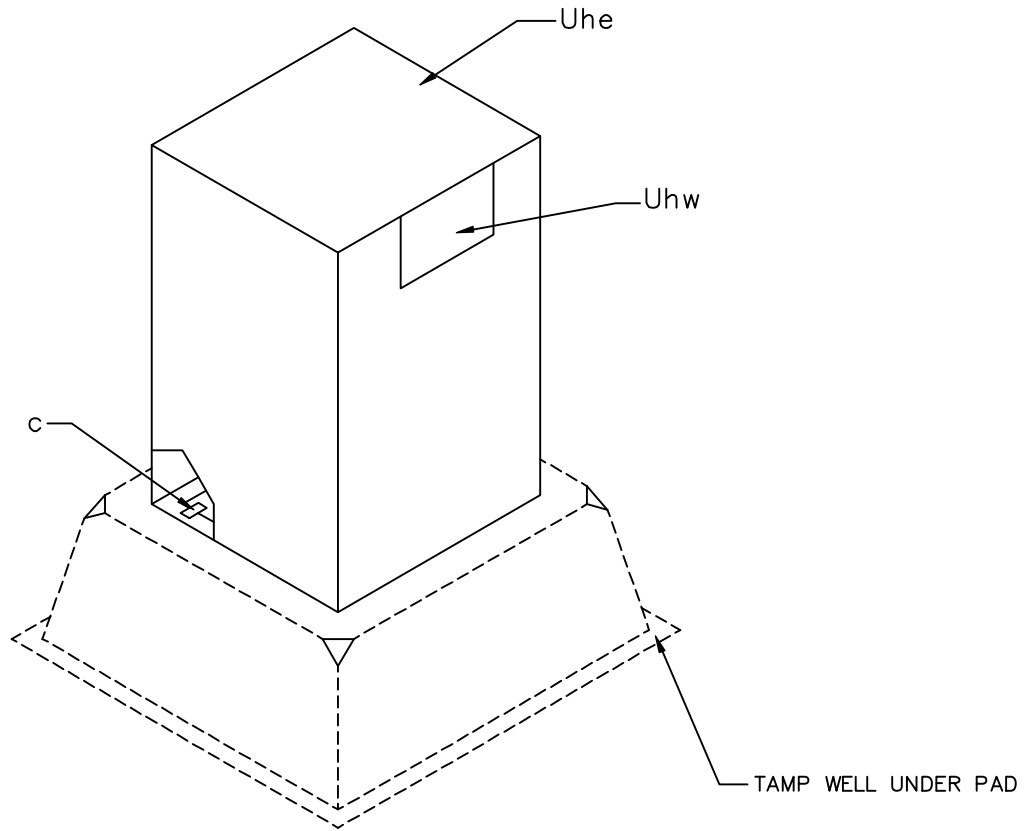

SPECIFICATION NUMBERING CODES:
 UM3E-(1,2 or 3) - (FIG. NO.)

SEE DRAWING UM3E-1, 2, OR 3
 NUMBER OF PHASES

EXAMPLE:

UM3E-3-9
 WIRING DIAGRAM
 THREE PHASE CONFIGURATION
 FUSE ENCLOSURE

NOTES:

1. PAD OR GROUND SLEEVE LOAD BREAK ELBOWS, STRESS CONES, FUSES OR SWITCH BLADES ARE NOT PART OF THIS ASSEMBLY. THEY SHOULD BE SPECIFIED SEPARATELY ON THE STAKING SHEETS.
2. TAMP WELL UNDER SLEEVE. LEAVE SLACK COIL OF CABLE IN GROUND SLEEVE.
3. PLACE 6" OF FILL AGAINST INSIDE EDGE OF GROUND SLEEVE.
4. ON DEAD FRONT FUSE ENCLOSURES USE GROUNDING ASSEMBLY TO BE SPECIFIED SEPARATELY.
5. TOP OF GROUND SLEEVE TO BE INSTALLED 3" ABOVE GROUND LEVEL.
6. INSTALL "DANGER" SIGN ON EQUIPMENT INSIDE ENCLOSURE. INSTALL "WARNING" SIGN ON OUTSIDE SURFACE OF ENCLOSURE.
7. GROUND SLEEVES ARE SPECIFIED.

ITEM	QTY.	MATERIAL		
C		Bolt, machine, as necessary		
Uhe	1	Enclosure as specified	FUSE / SWITCH ENCLOSURE INSTALLATION	
Uhw	2	Signs, "DANGER" and "WARNING"		
			2000	UM3E-__ -__

FIG. 1A

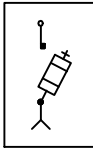

SINGLE PHASE
RADIAL FEED
1 - FUSE

FIG. 1B

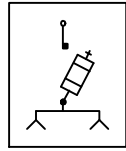

SINGLE PHASE
LOOP FEED
1 - FUSE

FIG. 1C

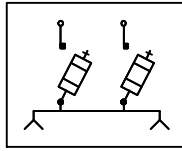

SINGLE PHASE
LOOP FEED
2 - FUSE

FIG. 1D

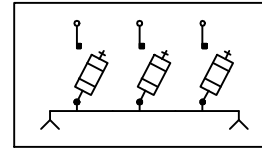

SINGLE PHASE
LOOP FEED
3 - FUSE

FIG. 1E

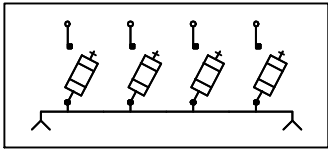

SINGLE PHASE
LOOP FEED
4 - FUSE

FIG. 1F

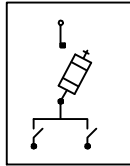

SINGLE PHASE
LOOP FEED
1 - FUSE

FIG. 1G

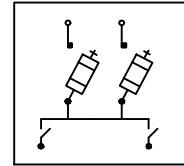

SINGLE PHASE
LOOP FEED
2 - FUSE

FIG. 2A

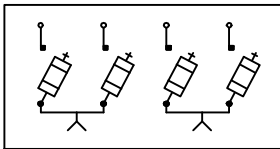

TWO PHASE
RADIAL FEED
2 - FUSE

FIG. 2B

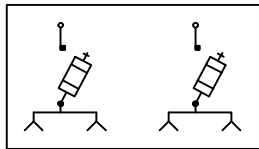

TWO PHASE
LOOP FEED
1 - FUSE

FIG. 2C

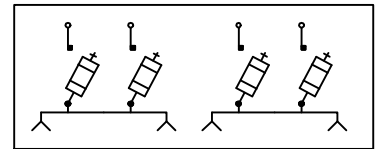

TWO PHASE
LOOP FEED
2 - FUSE

FIG. 2D

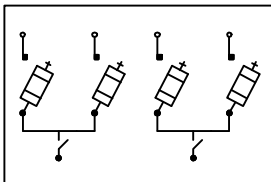

TWO PHASE
RADIAL FEED
2 - FUSE

FIG. 2E

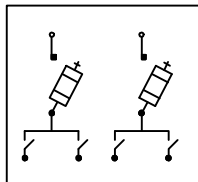

TWO PHASE
RADIAL FEED
1 - FUSE

FIG. 2F

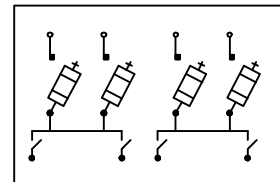

TWO PHASE
LOOP FEED
2 - FUSE

— FUSE

• — TERMINATIONS CAN BE WITH ELBOWS, STRESS CONES OR TERMINATORS

^ — LOADBREAK ELBOW LINE SWITCHING

— SINGLE POLE SOLID BLADE SWITCHING

SINGLE POLE SWITCHING
200 AMP FUSE ENCLOSURE
INSTALLATION WIRING DIAGRAMS
(SINGLE PHASE AND TWO PHASE)

2000

UM3E-1
UM3E-2

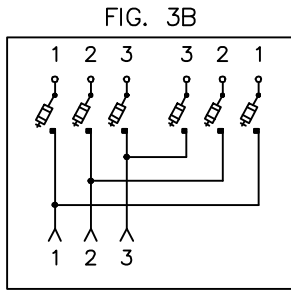

FIG. 3B
ELBOW SWITCH
2 - FUSE

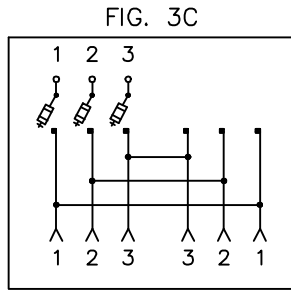

FIG. 3C
ELBOW SWITCH
1 - FUSE

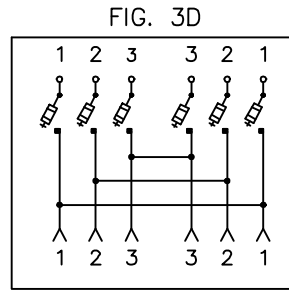

FIG. 3D
ELBOW SWITCH
2 - FUSE

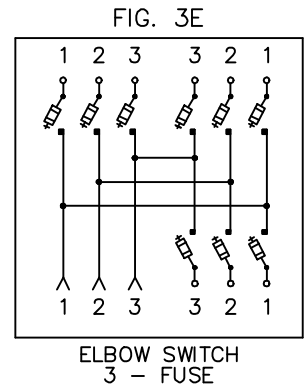

FIG. 3E
ELBOW SWITCH
3 - FUSE

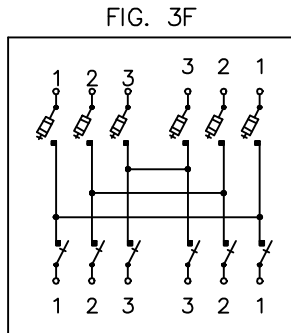

FIG. 3F
SINGLE POLE SWITCH
2 - FUSE

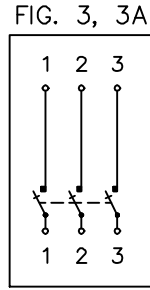

FIG. 3, 3A
THREE PHASE
SWITCH

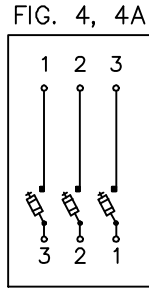

FIG. 4, 4A
THREE PHASE
SWITCH OR
FUSE

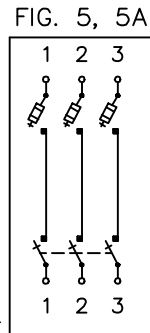

FIG. 5, 5A
THREE PHASE
SWITCH
1 - FUSE

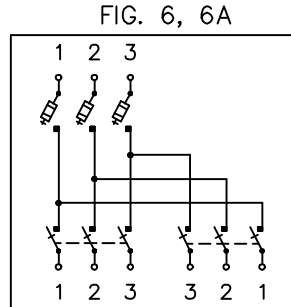

FIG. 6, 6A
THREE PHASE
SWITCHES
1 - FUSE

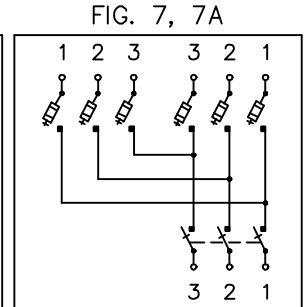

FIG. 7, 7A
THREE PHASE
SWITCH
2 - FUSE

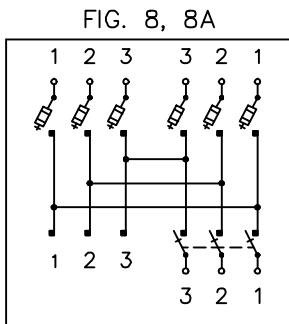

FIG. 8, 8A
THREE PHASE SWITCH
2 - FUSE
1 - TERMINAL

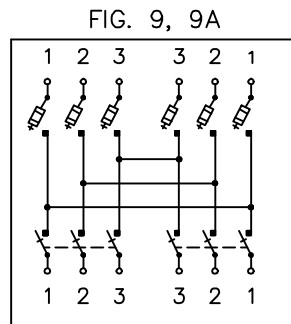

FIG. 9, 9A
THREE PHASE SWITCHES
2 - FUSES

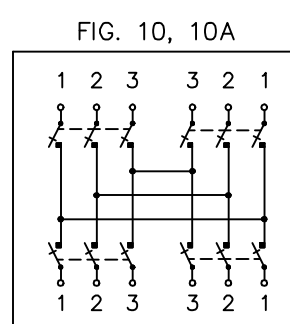

FIG. 10, 10A
THREE PHASE SWITCHES

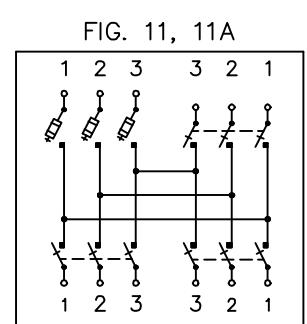

FIG. 11, 11A
THREE PHASE SWITCHES
1 - FUSE

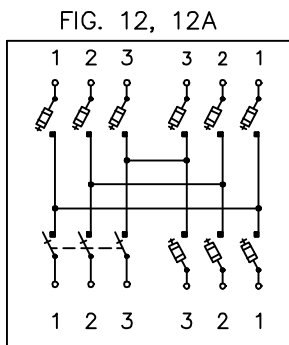

FIG. 12, 12A
THREE SWITCH
3 - FUSES

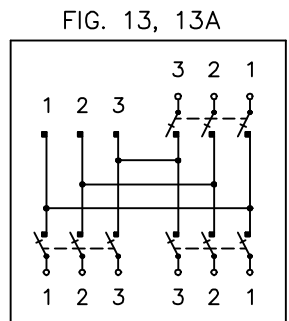

FIG. 13, 13A
THREE PHASE SWITCHES
1 - TERMINAL

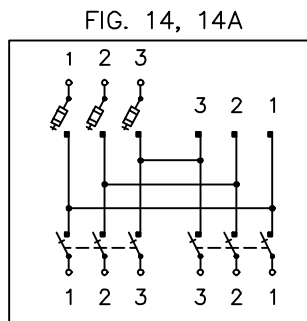

FIG. 14, 14A
THREE PHASE SWITCHES
1 - FUSE
1 - TERMINAL

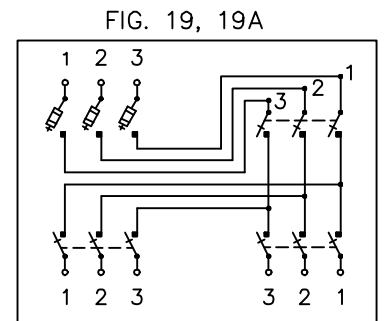

FIG. 19, 19A
THREE PHASE SWITCHES
THREE PHASE SWITCHED / FUSE TAP

EXAMPLE:

FIG. 3 = 600 AMP MAIN
LINE SWITCH

FIG. 3A = 200 AMP MAIN
LINE SWITCH

□ - FUSE

• - TERMINATIONS CAN BE
WITH ELBOWS, STRESS
CONES OR TERMINATORS

∧ - LOADBREAK ELBOW LINE
SWITCHING

FUSE ENCLOSURE (200 - 600 AMP)
WIRING DIAGRAMS
(THREE PHASE)

2000

UM3E-3

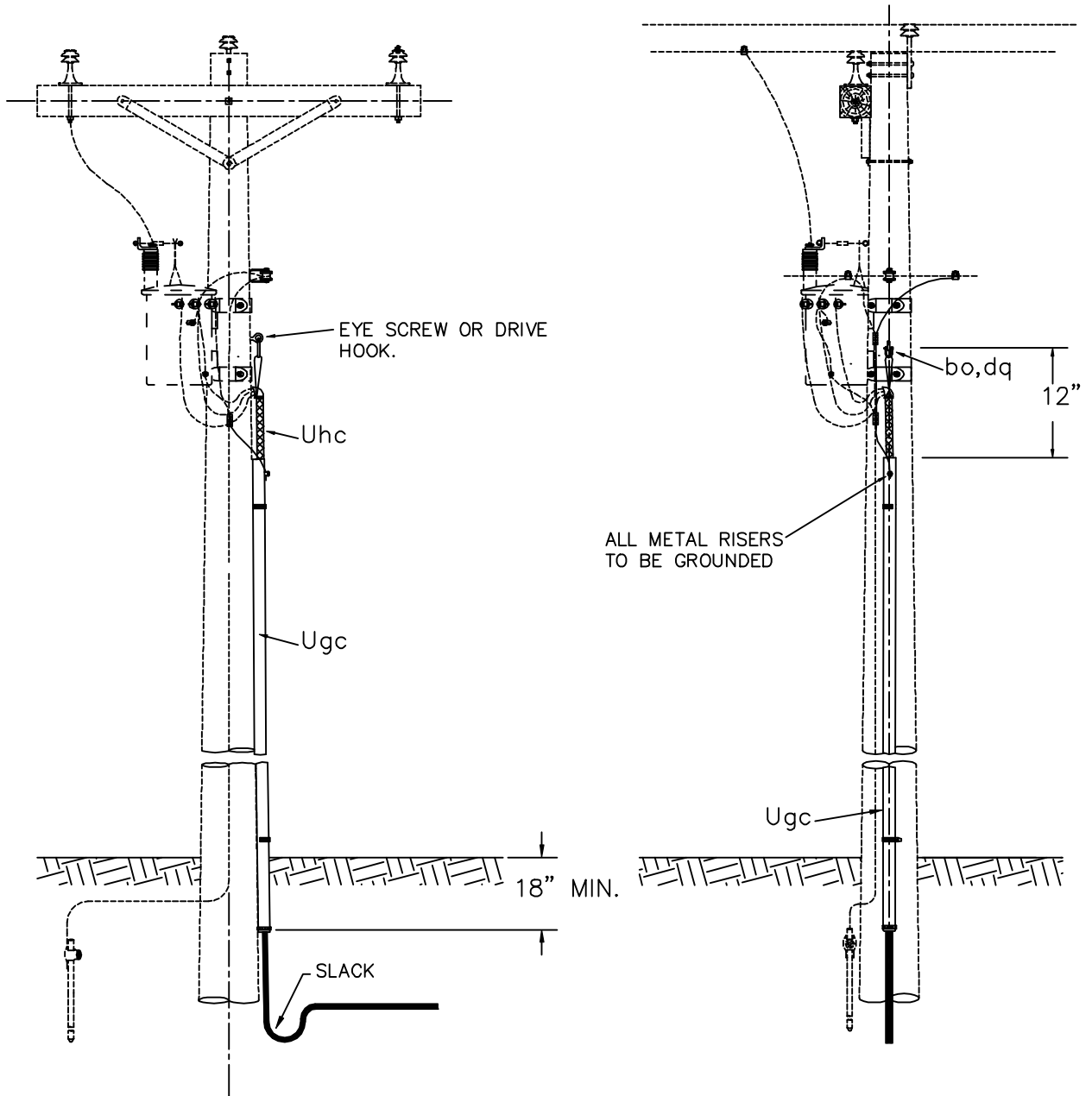

NOTES:

1. ALLOW MINIMUM CABLE SLACK OF 24" AT BOTTOM OF RISER.

ITEM	QTY.	MATERIAL
bo		Anchor, shackle. Do not use if drive hook is used.
dq	1	Eye screw, elliptical or drive hook.
Ugc	1	Cable riser shield. Length as required.
Uhc	1	Cable support.

SECONDARY CABLE TERMINAL POLE

2000

UM5

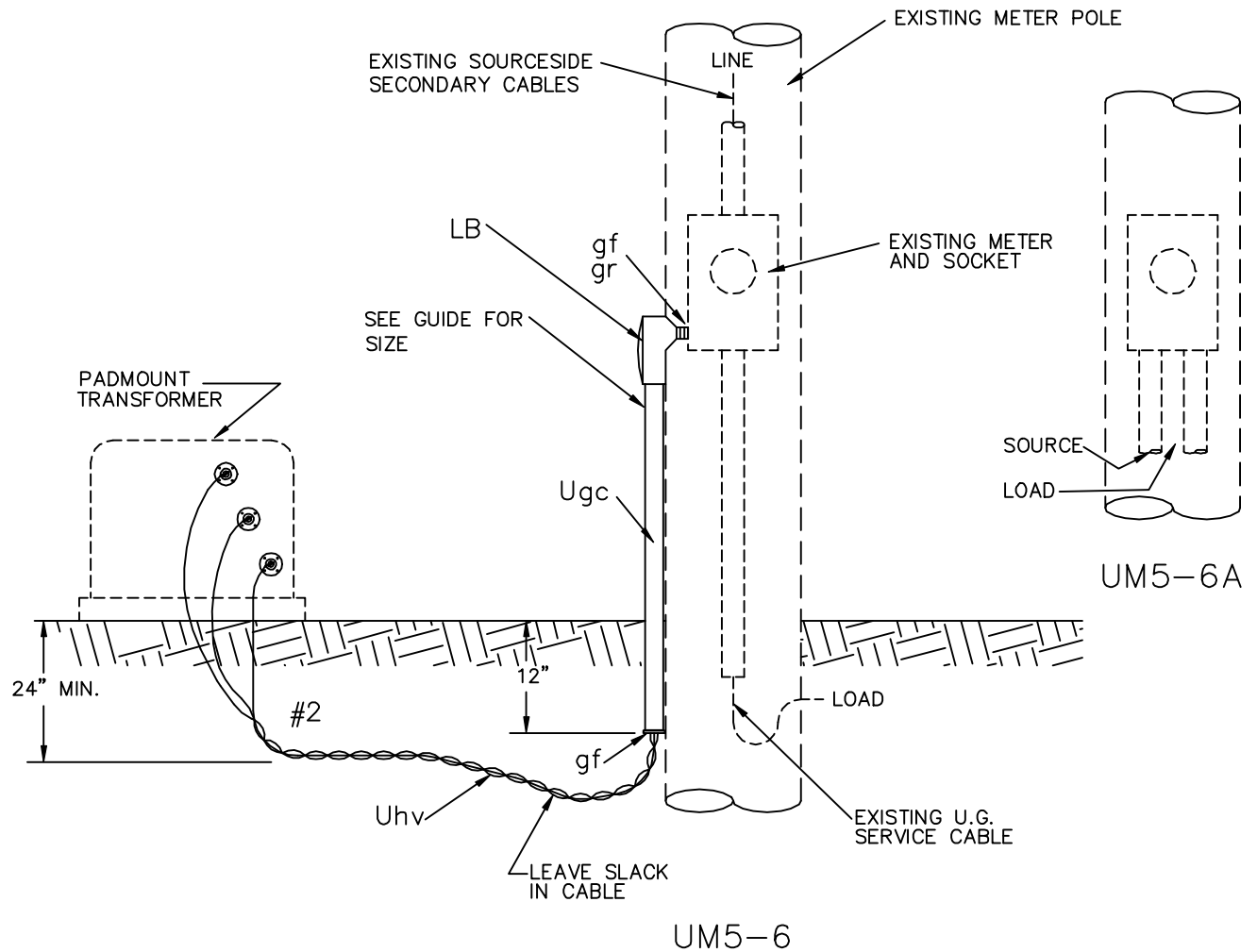

NOTES:

1. DISCONNECT SOURCESIDE CONDUCTORS IN METER SOCKET.
2. CONNECT NEW CABLE TO SOURCESIDE OF METER SOCKET.
3. SECONDARY CABLE, UNIT Uhv, SPECIFIED ON SEPARATE UNIT.
4. IF UNIT UM5-6A IS SPECIFIED, EXISTING METER SOCKET AND TYPE "LB" CONDUIT FITTING ARE REPLACED BY A METER SOCKET WITH TWO CONDUIT KNOCKOUTS ON BOTTOM SIDE.

ITEM	QTY.	MATERIAL		
gf	2	Bushings, insulated		
gr	2	Locknut		
	1	Type "LB" conduit fitting		
	1	conduit short nipple, with bushing		
Ugc		Conduit, as required		
Uhv		Cable, underground, 600 V, as required		
			SECONDARY CABLE TERMINAL TO METER BASE	
			2000	UM5-6 UM5-6A

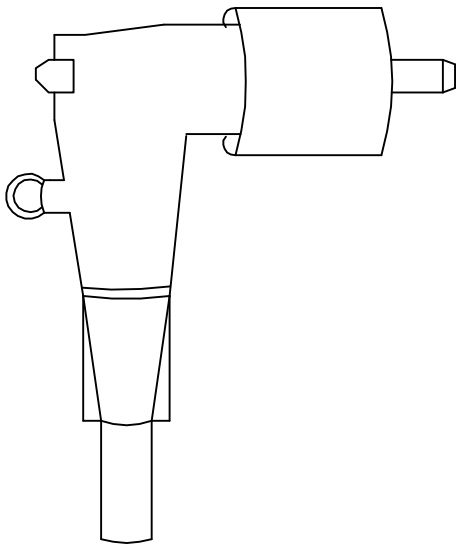

UM6-1 Uhp
LOAD BREAK ELBOW
(200 A)

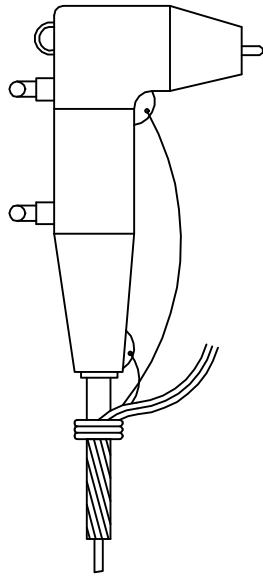

UM6-2 Uhp
FUSED ELBOW TERMINATION
(200 A)

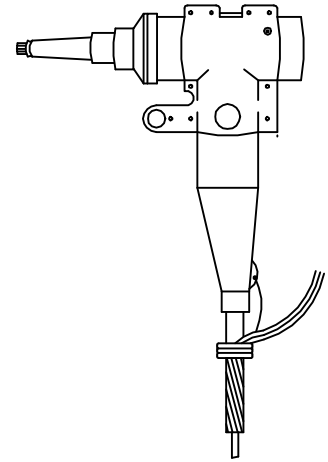

UM6-3 Uhb
DEAD BREAK TERMINATION
(600 A)

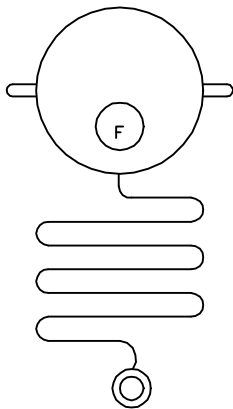

UM6-4 Ugo
FAULT INDICATOR

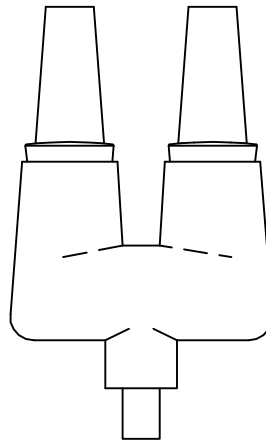

UM6-5 Uhb
FEED THROUGH LOAD BREAK INSERT

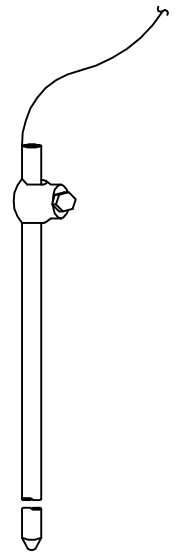

UM6-6 ai, aj, cj
GROUND ROD ASSEMBLY

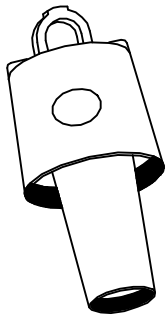

UM6-7 Uhb
BUSHING WELL PLUG
(200 A)

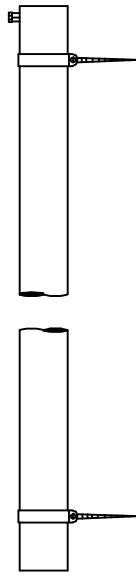

UM6-8 Ugc
RISER SHIELD (U GUARD)



UM6-9 Ugc
CONDUIT CABLE RISER

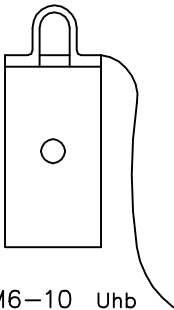

UM6-10 Uhb
INSULATED PROTECTIVE CAP
(200 A)

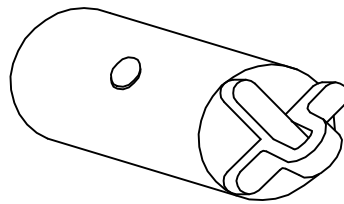

UM6-11 Uhb
INSULATED PROTECTIVE CAP
(600 A)



UM6-12 Uhx
CABLE MARKER ASSEMBLY

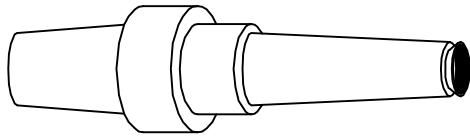

UM6-13 Uhb
LOAD BREAK INSERT
(200 A)

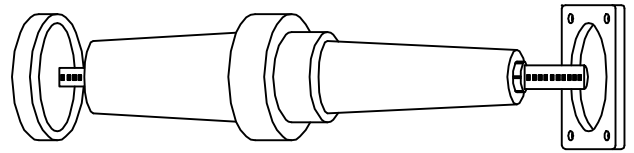

UM6-14 Uhb
DEADBREAK INSERT
(600 A)

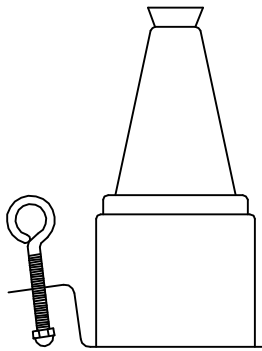

UM6-15 Uhq
STAND-OFF INSULATOR
(200 A)

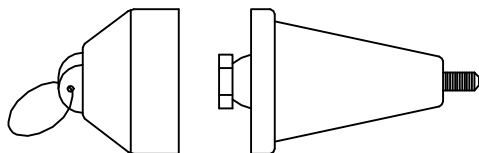

UM6-17 Uhb
INSULATING PLUG
600 AMP CONNECTOR

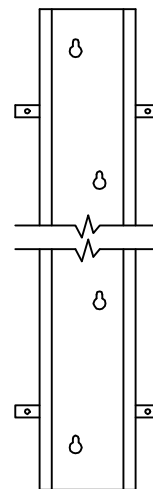

UM6-18
BACKING PLATE FOR
U-GUARD RISER SHIELD

MISCELLANEOUS ACCESSORIES

2000

Page 3 of 8

UM6-__

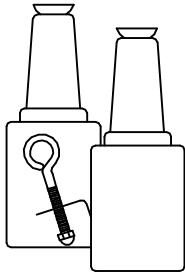

UM6-19 Uhq
STAND-OFF INSULATOR
FEED THROUGH
(200 A)

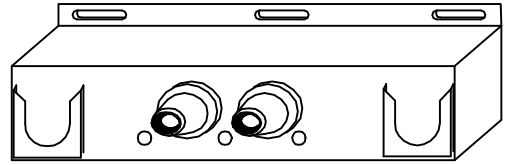

UM6-20 Uhq
TWO POINT JUNCTION
(200 A)

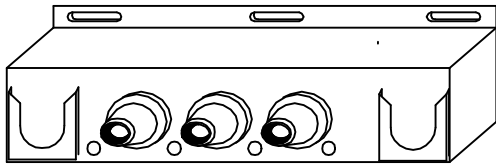

UM6-21 Uhq
THREE POINT JUNCTION
(200 A)

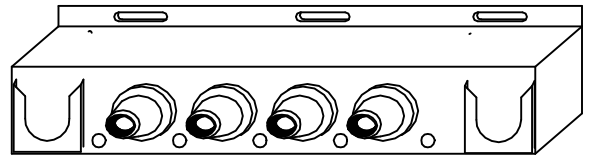

UM6-22 Uhq
FOUR POINT JUNCTION
(200 A)

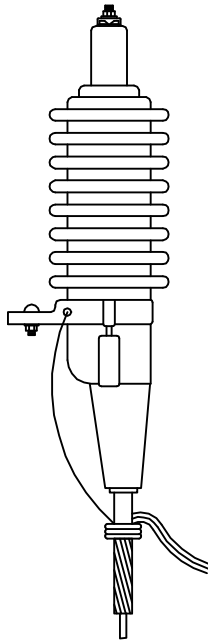

UM6-24 Ugk
OUTDOOR TERMINATION

MISCELLANEOUS ACCESSORIES

2000

Page 4 of 8

UM6-__

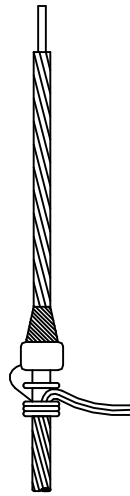

UM6-26 U_{gk}
INDOOR STRESS RELIEF CONE

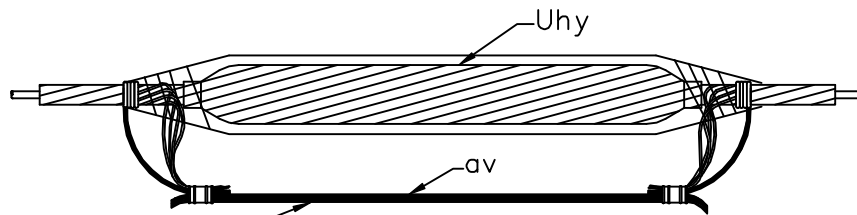

CONCENTRIC NEUTRAL
OR
EQUIVALENT EXTENSION

UM6-28 U_{hy}
IN LINE PRIMARY SPLICE
(FOR JACKETED CABLE)

NOTES:

1. Jacketed cable restoration and termination sealing kits (items U_{hf}) are available for resealing concentric neutral wires after installation of splices, elbows, and outdoor terminations; also for connecting a grounding lead wire to the concentric neutral wires and resealing the jacket.

			MISCELLANEOUS ACCESSORIES	
2000	Page 5 of 8	UM6-__		

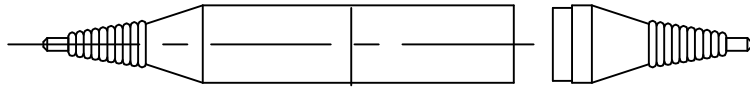

UM6-32 U_{gq}
BOOT OR SLEEVE - INSULATED
(600 VOLT)

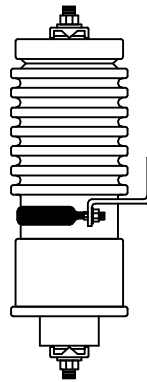

UM6-33 U_{ae}
SURGE ARRESTER

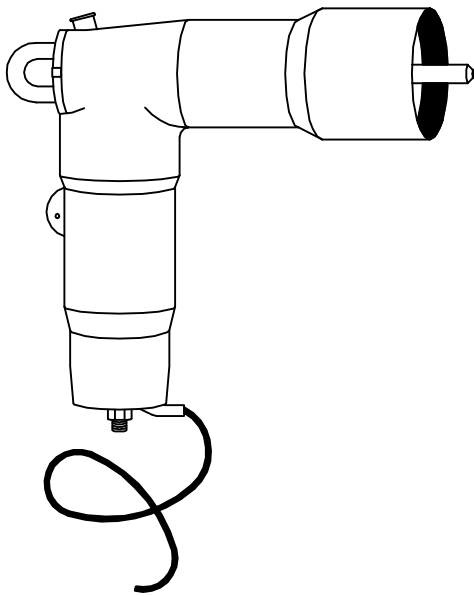

UM6-34 U_{ae}
DEAD BREAK ELBOW
SURGE ARRESTER

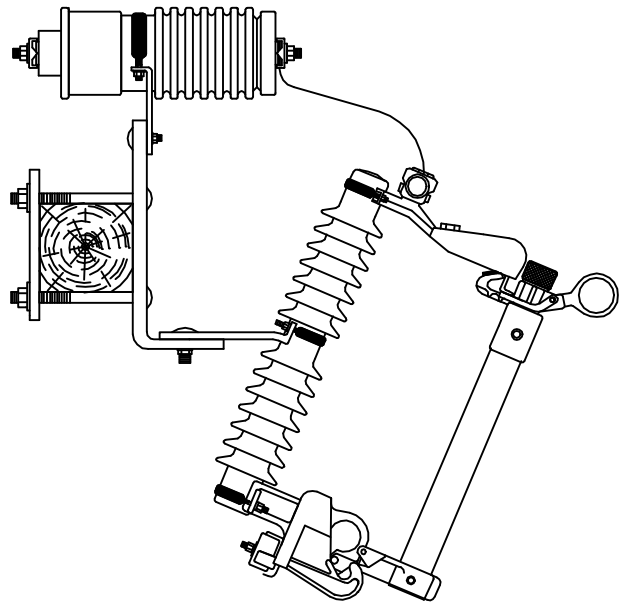

UM6-35 U_{ax}
CUTOUT-ARRESTER COMBINATION

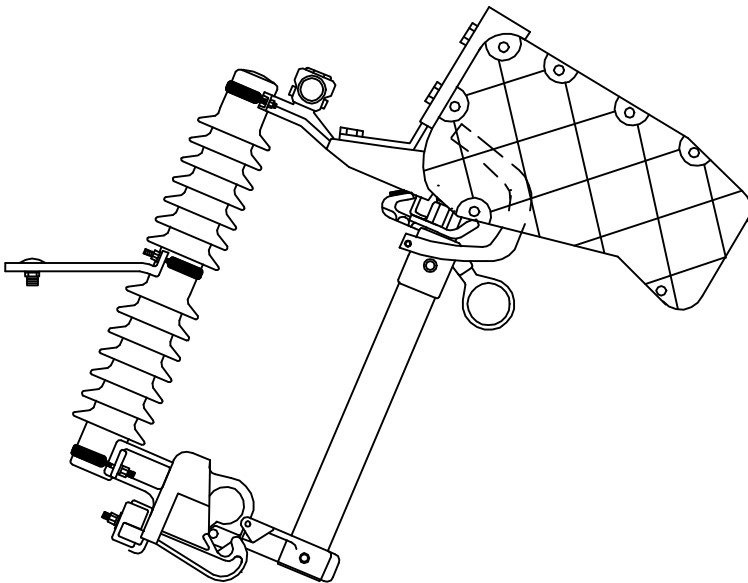

UM6-36 of
LOAD BREAK CUTOUT

MISCELLANEOUS ACCESSORIES		
2000	Page 7 of 8	UM6-__

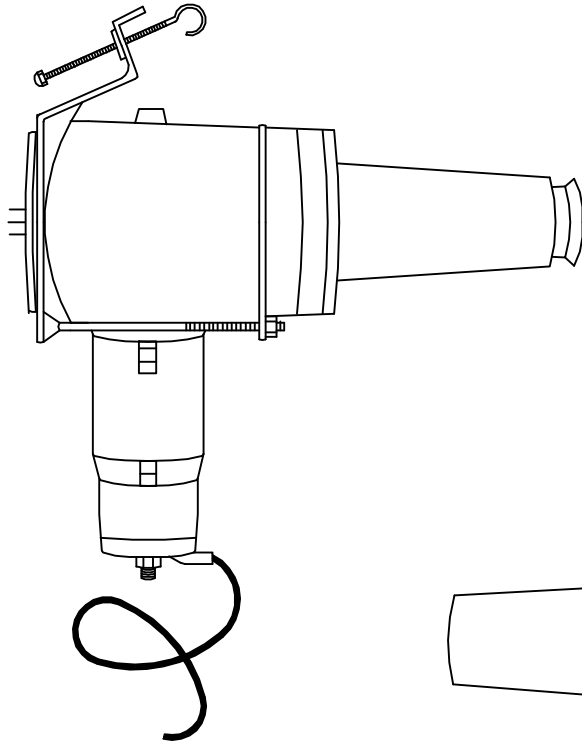

UM6-37 Uae
PARKING STAND ARRESTER

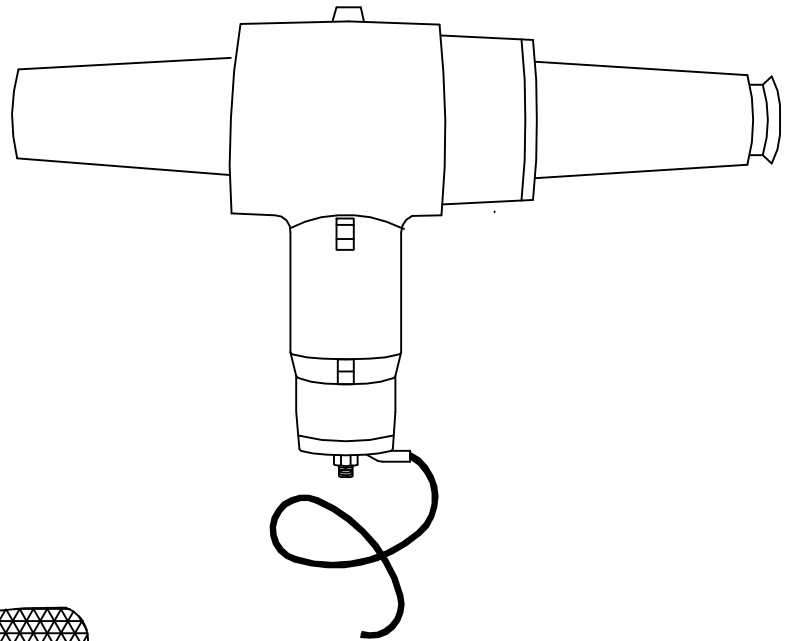

UM6-38 Uae
BUSHING ARRESTERS

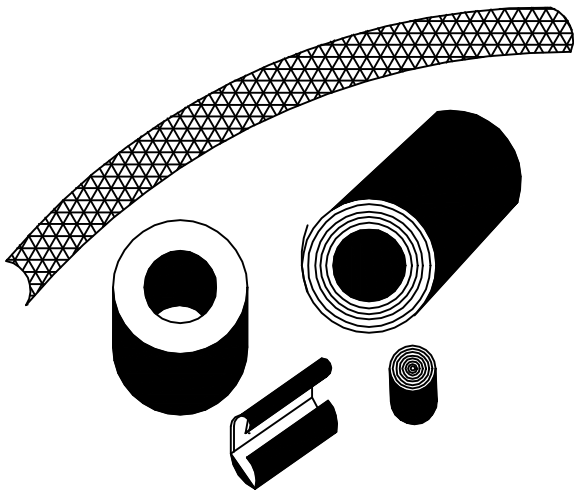

UM6-39 Uhf
JACKETED CABLE GROUNDING KITS

			MISCELLANEOUS ACCESSORIES		
2000		Page 8 of 8		UM6-__	

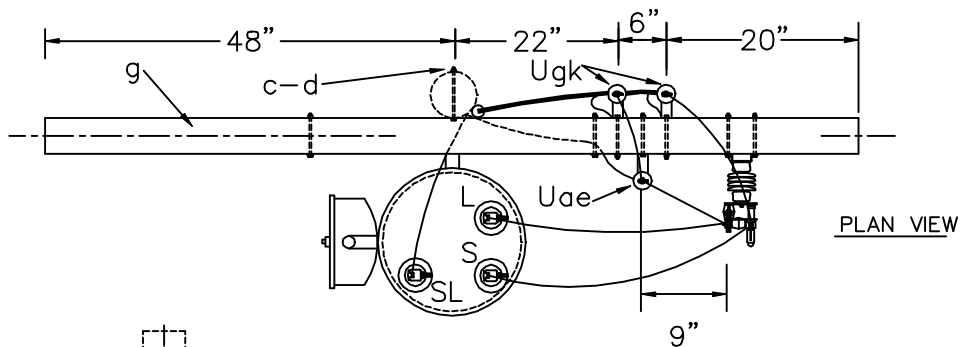

PLAN VIEW

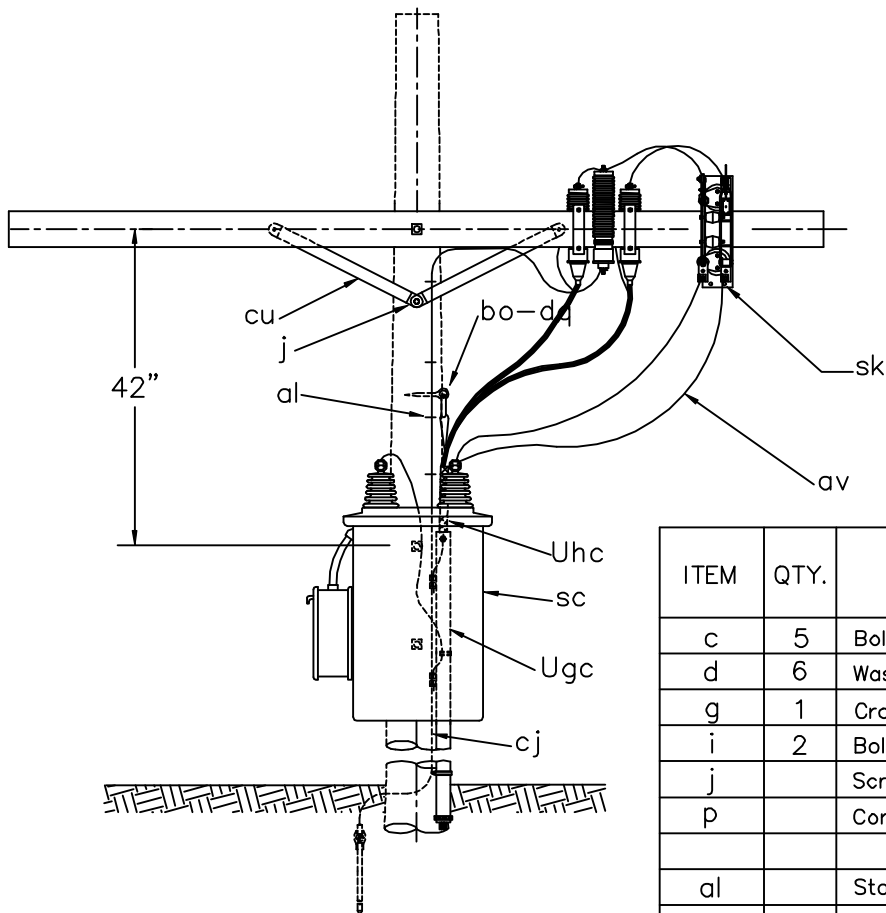

NOTES:

1. Three of these assemblies may be used for three phase installation.
2. Total arrester lead length must be under 3 feet if possible.
3. All clearances must meet NESC requirements.

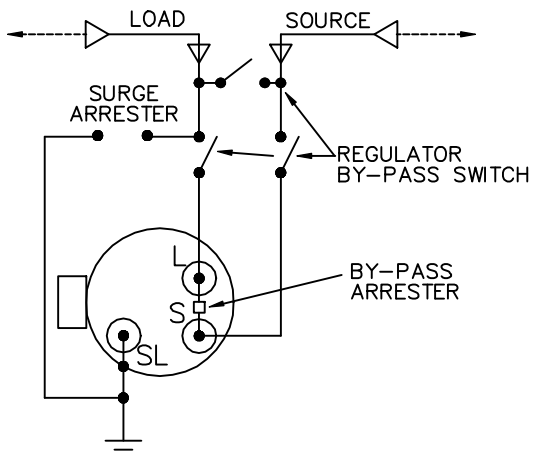

WIRING DIAGRAM

ITEM	QTY.	MATERIAL
c	5	Bolt, machine, 5/8" x required length.
d	6	Washer, square 2 1/4".
g	1	Crossarm, 3 5/8" x 4 5/8" x 8'-0".
i	2	Bolt, carriage, 3/8" x 4 1/2"
j		Screw, lag 1/2" x 4" as required.
p		Connectors, as required.
al		Staples, as required.
av		Jumpers, as required.
bo	1	Anchor, shackle. Omit if drive hook is used.
cj		Ground wire, as required.
cu	2	Brace, wood, 28"
dq	1	Eye screw, elliptical or drive hook.
ek		Locknuts
fn	1	Bracket, cutout, extension.
sc	1	Regulator, step type.
sk	1	Regulator, by-pass switch.
Uae	1*	Surge arrester
Ugc	1	Cable riser shield. Length as required.
Ugk	2	Cable termination.
Uhc	2	Cable support.
Uhd	2	Crossarm mounting bracket.

SINGLE PHASE REGULATOR ASSEMBLY WITH BY-PASS SWITCHING FUNCTION UNDERGROUND TO UNDERGROUND

2000

UM7-1

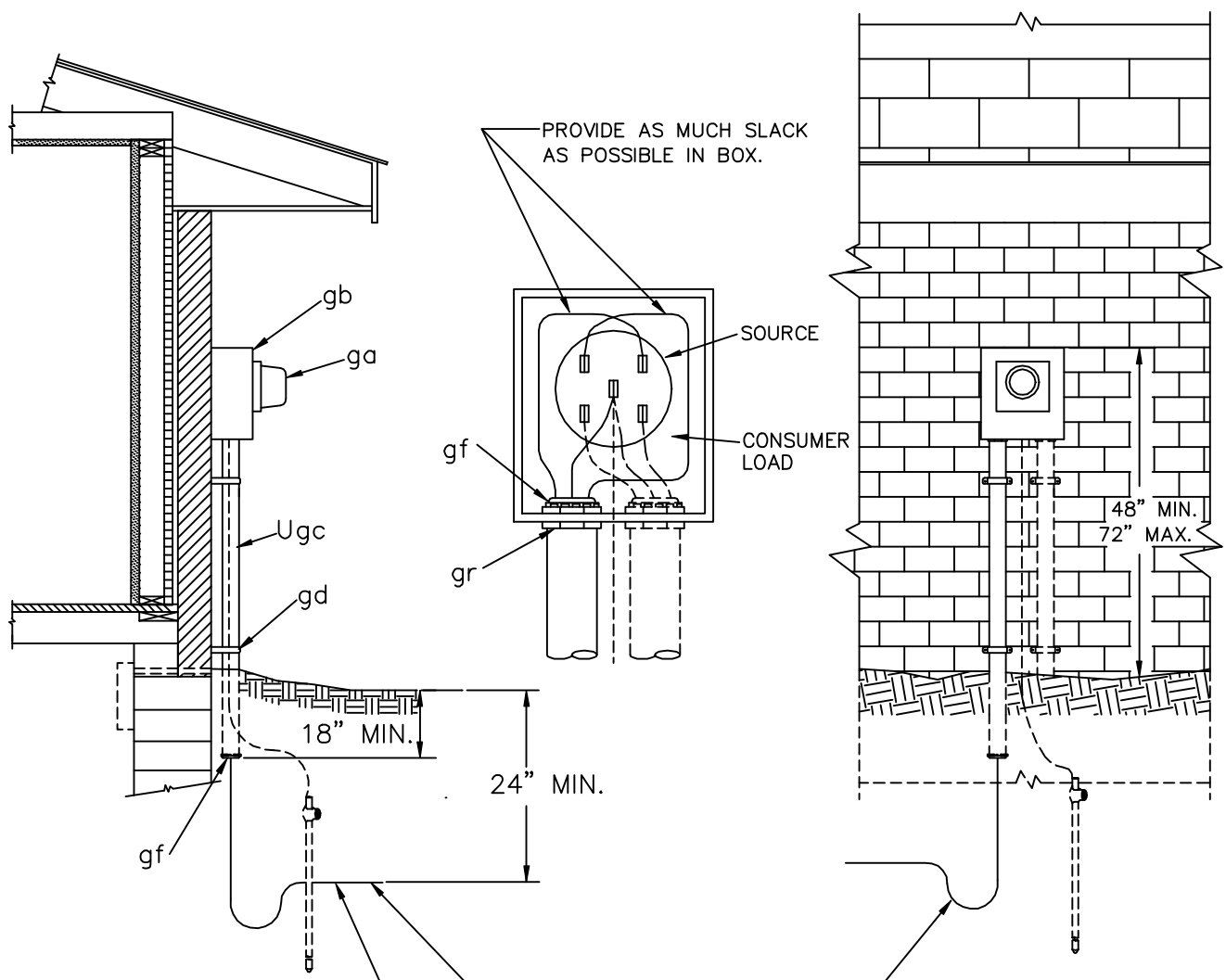

HAND TAMP, PREFERABLY WITH PNEUMATIC TOOL. BACKFILL WITH CLEAN MATERIAL.

SLACK SHALL BE PROVIDED TO PREVENT DAMAGING STRAIN ON THE CABLE AFTER BACKFILLING.

ITEM	QTY.	MATERIAL
ga	1	Meter, as required
gb	1	Meter socket
gd	2	Pipe strap
gf	2	Insulated bushing, size as required
gr	2	Conduit locknuts, size as required
Ugc	1	Conduit, diameter and length as required

METER INSTALLATION UNDERGROUND SOURCE		
	2000	UM8

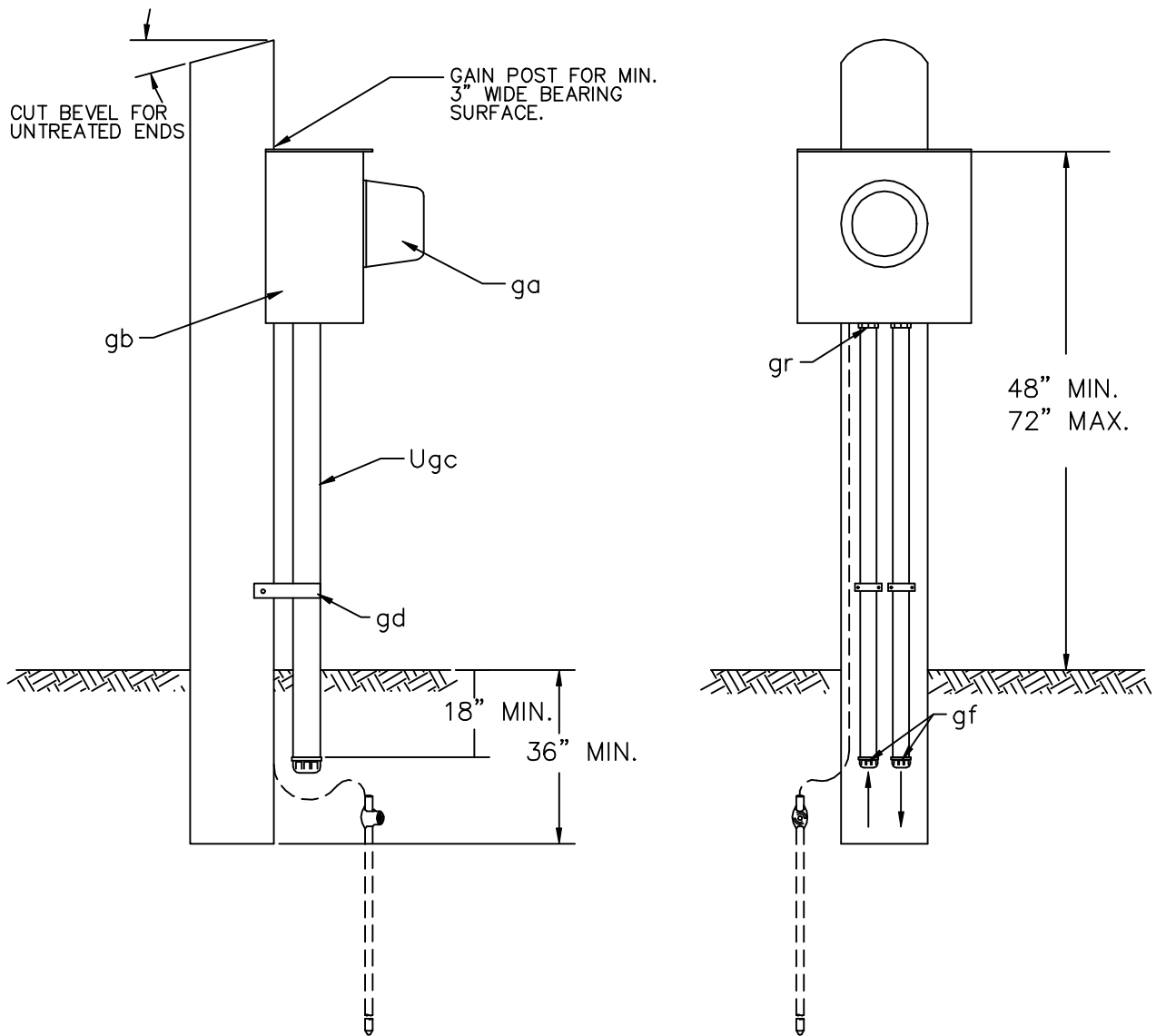

NOTE: MINIMUM POST SIZE SHALL BE FOUR INCHES SQUARE OR IN DIAMETER.

ITEM	QTY.	MATERIAL
	1	Wood post, approx. 9 ft. long, treated
ga	1	Meter, as required
gb	1	Meter socket
gd	1	Pipe strap
gf	2	Insulated bushings, size as required
gr	2	Conduit locknuts, size as required
Ugc	2	Conduit, diameter and length as required

METER PEDESTAL WOOD POST		
	2000	UM8-2

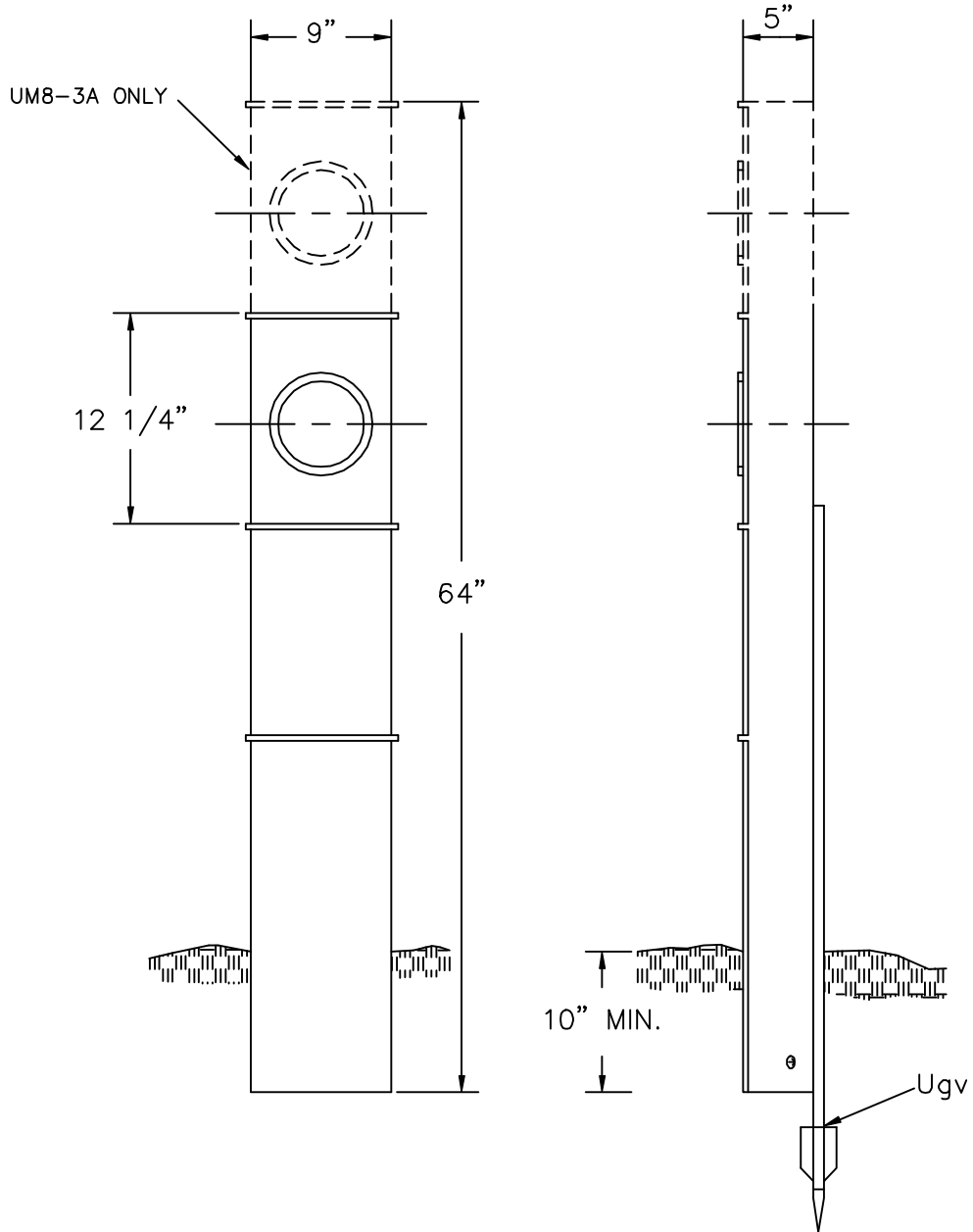

ITEM	QTY.	MATERIAL		
	1	Meter, pedestal, 200 A Main, 200 Amp. per position (UM8-3)		
	1	Meter, pedestal, 400 A Main, 200 Amp. per position (UM8-3A)		
			TROUGH TYPE METER PEDESTAL	
Ugv	1	Stake, support	2000	UM8-3 UM8-3A

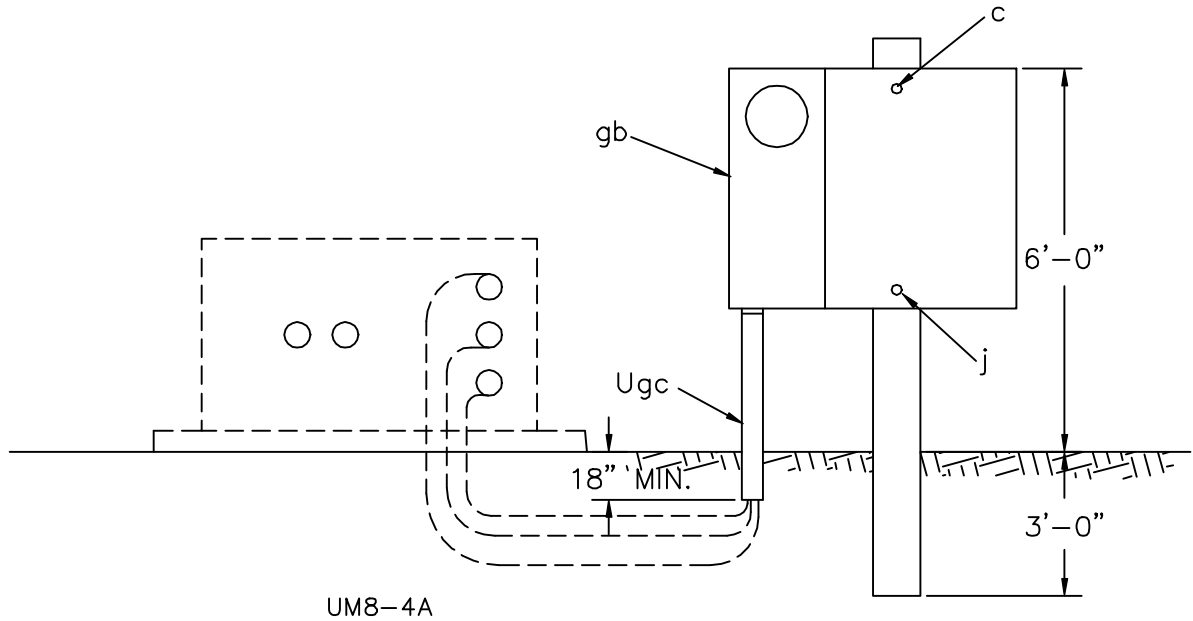

UM8-4A

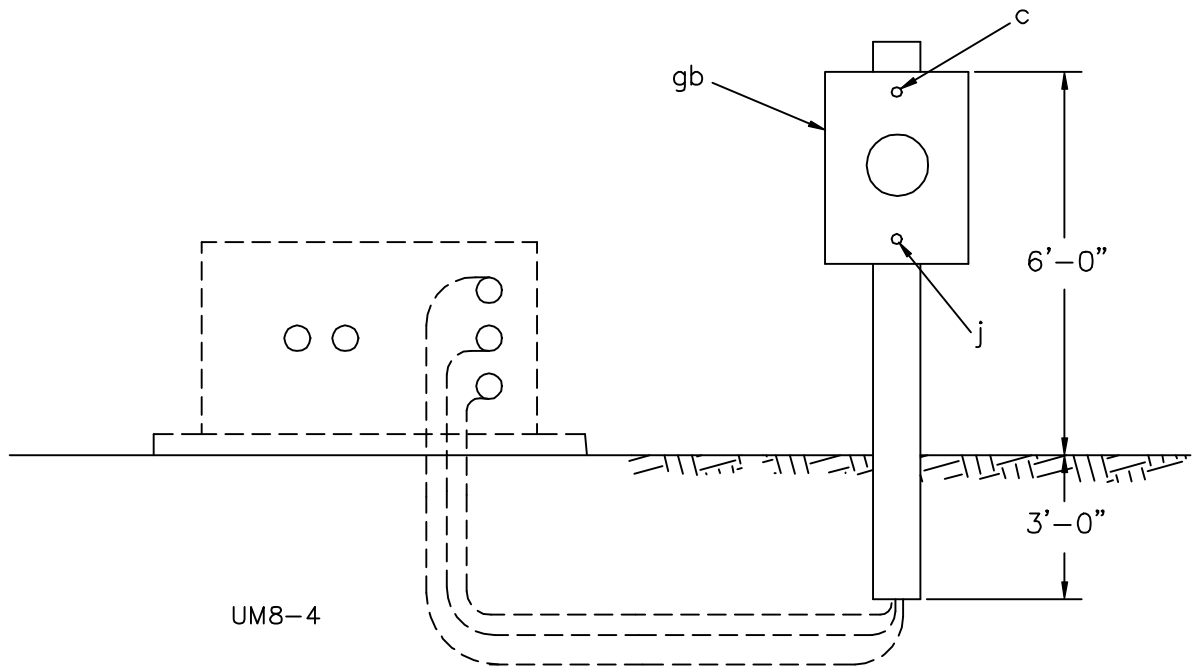

UM8-4

ITEM	QTY.	MATERIAL
		Stub pole, 9'-0"
		Switch, as required
c	1	Machine bolt, 1/2" x 10"
d	1	Washer, square, 2" x 2"
j	1	Lag screw, 1/2" x 4"
ek	1	Locknut, 1/2"
gb		Meter base, as required
Ugc		Conduit, as required

METER & SWITCH INSTALLATION
UNDERGROUND SOURCE

2000

UM8-4
UM8-4A

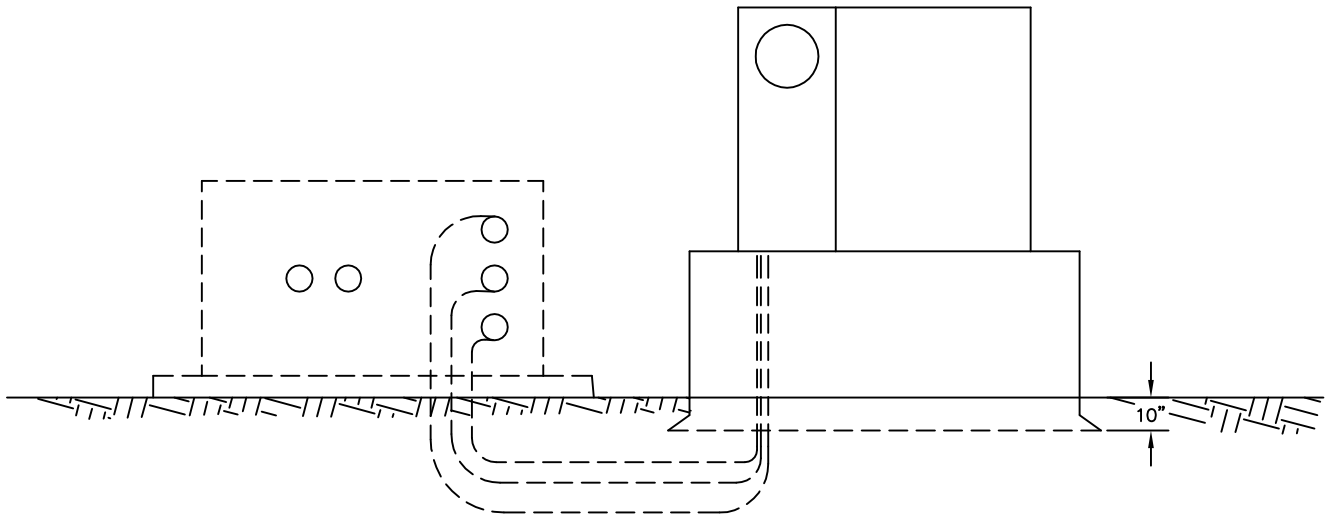

NOTE:
SPECIFY PAD OR SLEEVE UNIT SEPARATELY

ITEM	QTY.	MATERIAL	PAD MOUNTED SWITCH INSTALLATION UNDERGROUND SOURCE	
	1	Switch, as required		

METHOD 1

PREFERRED METHOD FOR INSTALLATION OF METERING IS TO MOUNT METER SOCKET ON BUILDING WALL.

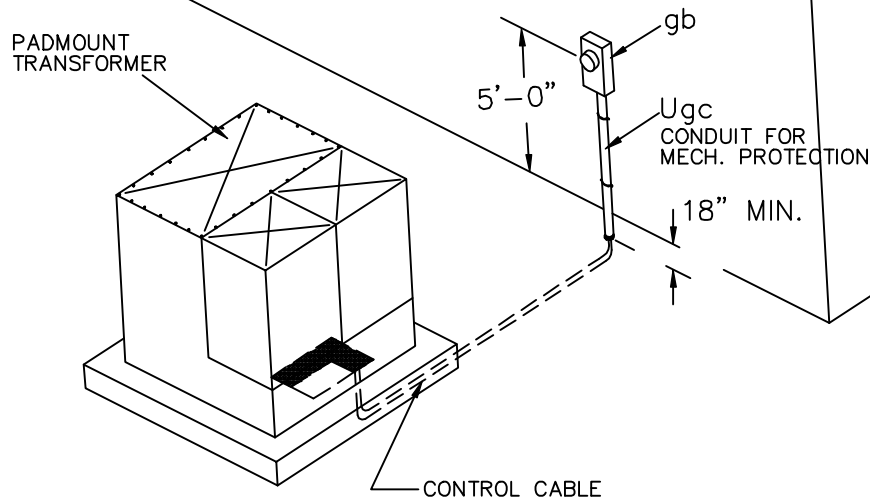

METER HEIGHT SHALL BE 5'-0" TO CENTER OF METER.

METER SOCKET MUST NOT BE ATTACHED DIRECTLY TO PADMOUNTED TRANSFORMER.

CONDUIT SHALL BE USED FOR SECONDARY CONTROL WIRES TO METER SOCKETS.

METHOD 2

METHOD TO USE IF METER CABINET MUST BE MOUNTED FREE STANDING.

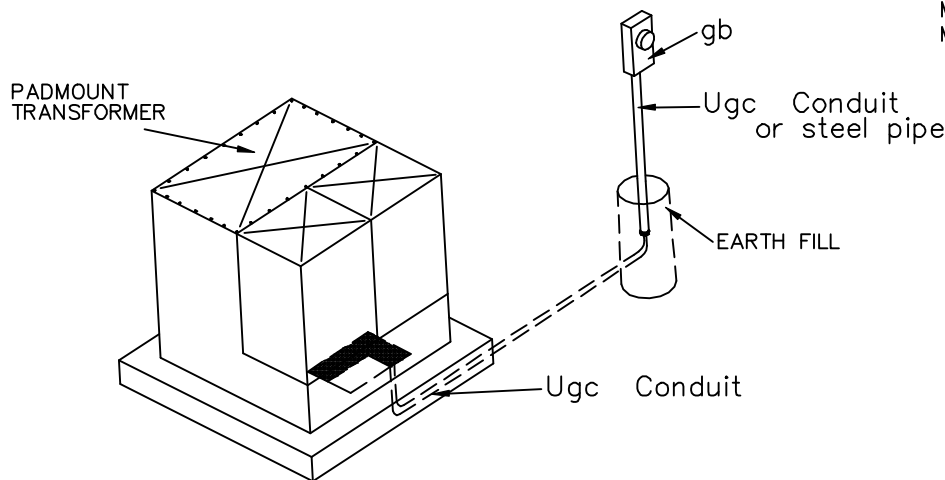

METER SOCKET MUST NOT BE ATTACHED DIRECTLY TO PADMOUNTED TRANSFORMER.

4'-0" MINIMUM HEIGHT TO CENTER OF METER.

CONDUIT SHALL BE USED FOR SECONDARY CONTROL WIRES TO METER SOCKET.

NOTE: CT & PT TO BE MOUNTED AS REQUIRED IN TRANSFORMER ENCLOSURE.

ITEM	QTY.	MATERIAL
		Control cable, as required
		Pipe strap, as required
gb	1	Meter socket
se		Potential transformer, as required
Ugc		Steel pipe, as required
Ugc		Conduit, as required
Usd		Current transformer, as required

C.T. METER INSTALLATION
SINGLE PHASE

2000

UM8-6

- UM8-7-A METER ON BUILDING
- UM8-7-B METER ON TAP BOX
- UM8-7-C METER ON LOAD CENTER

METER SOCKET MUST NOT BE ATTACHED DIRECTLY TO PADMOUNTED TRANSFORMER.

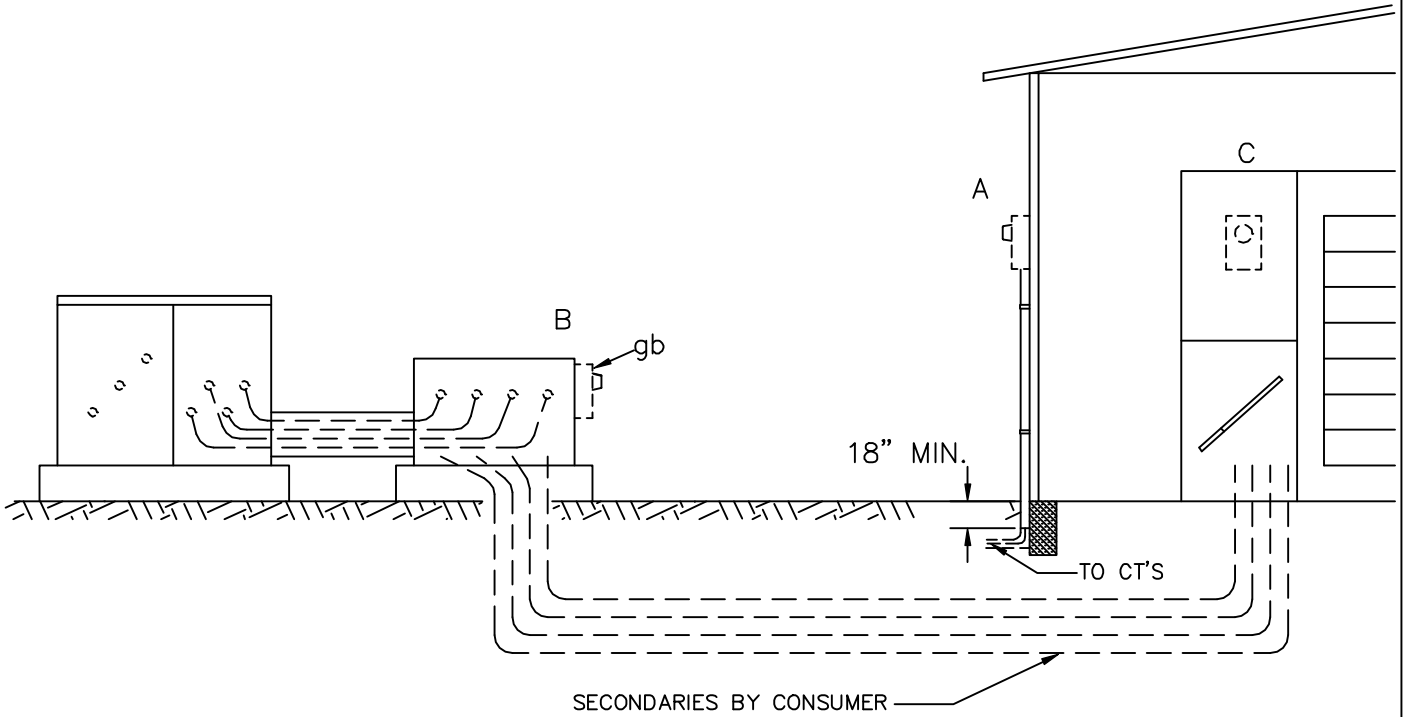

ITEM	QTY.	MATERIAL
		Control cable, as required
		Pipe strap, as required
gb	1	Meter socket
se		Potential transformer, as required
Ugc		Conduit, as required
Ugc		Steel pipe, as required
Usd		Current transformer, as required

C.T. METER INSTALLATION THREE PHASE	
2000	UM8-7-__

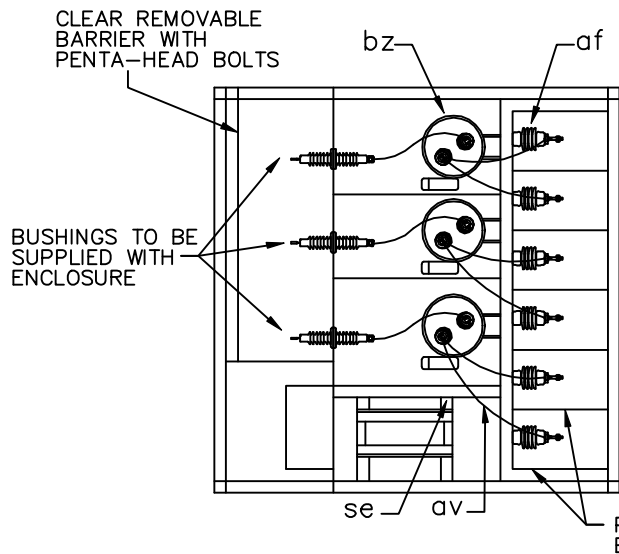

TOP VIEW

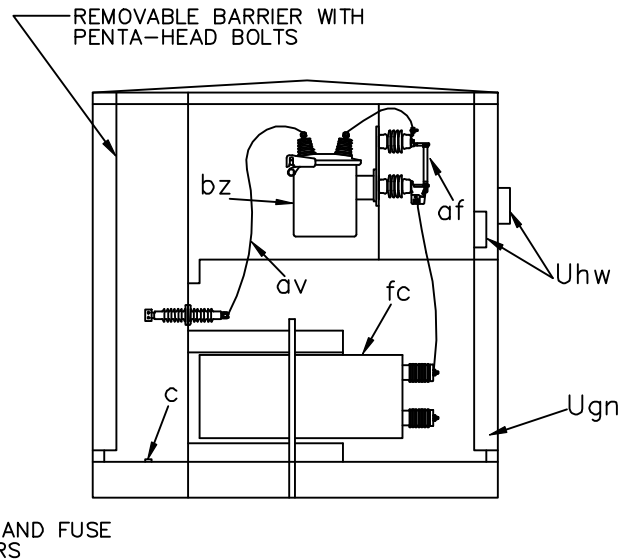

SIDE VIEW

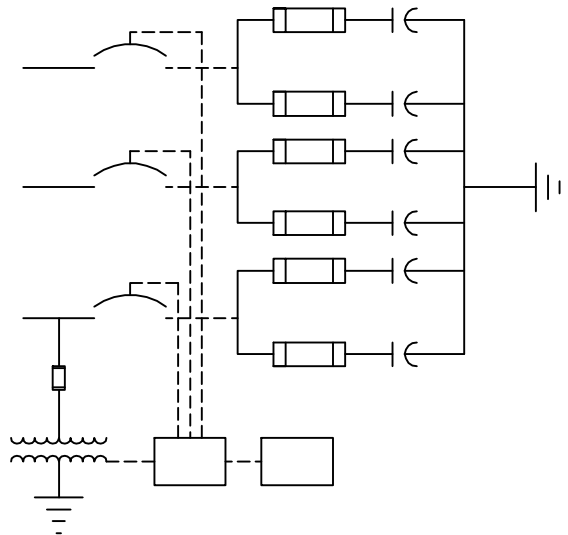

ONE LINE DIAGRAM

ITEM	QTY.	MATERIAL
C		Bolts, machine, as required
af	6	Power fuse, current limiting
av		Jumpers, copper, as required
bz	3	Single phase oil switch
fc	6	Shunt capacitor
se	1	Potential transformer line voltage to 120 VAC
	3	Bushing with spade
Ugn	1	Enclosure, as specified
Uhw	2	Signs, "DANGER" and "WARNING"

NOTES:

1. LOAD BREAK ELBOWS, STRESS CONES, FUSES OR SWITCH BLADES; GROUND SLEEVE IS NOT PART OF THIS ASSEMBLY. THEY SHOULD BE SPECIFIED SEPARATELY ON THE STAKING SHEETS.
2. TAMP WELL UNDER SLEEVE, LEAVE SLACK COIL OF CABLE IN GROUND SLEEVE.
3. PLACE 6" OF FILL AGAINST INSIDE EDGE OF GROUND SLEEVE.
4. GROUNDING UNIT TO BE SPECIFIED SEPARATELY.
5. INSTALL "WARNING" SIGN ON OUTSIDE OF ENCLOSURE AND "DANGER" SIGN INSIDE ENCLOSURE.

PAD MOUNTED SWITCHED
CAPACITOR ENCLOSURE

2000

UM9-2

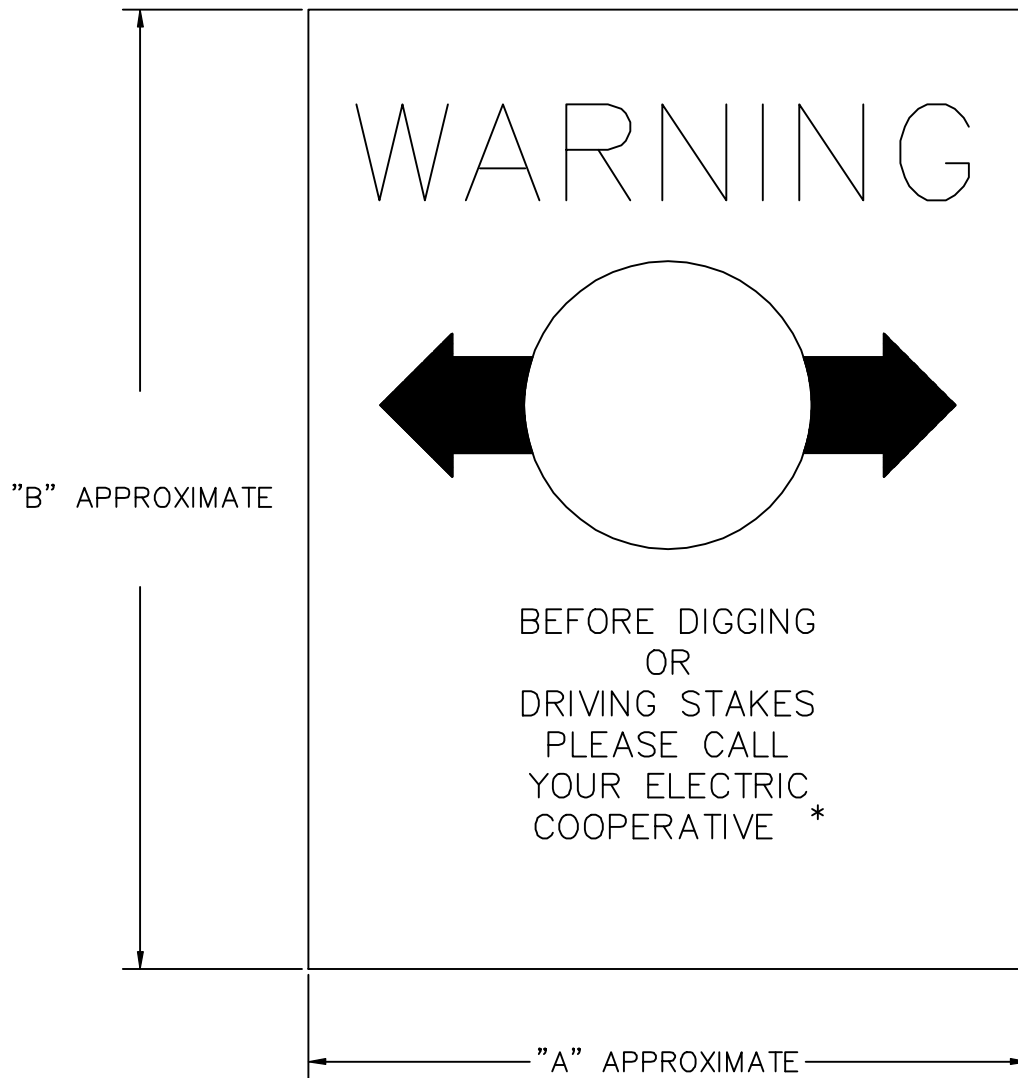

* COOPERATIVE NAME AND TELEPHONE NUMBER MAY BE INSERTED AS AN ALTERNATE.

NOTES:

1. BACKING MATERIAL SHALL BE 16 GAUGE GALVANIZED STEEL, OR EQUAL.
2. SIGN SHALL HAVE A YELLOW BACKGROUND WITH BLACK LETTERS.
3. SIGN SHALL BE SUPPORTED AND DISPLAYED AS SPECIFIED BY OWNER.
4. SIGN SHALL MEET ANSI Z535 STANDARD.

WIDTH ("A")	HEIGHT ("B")
4"	5"
7"	12"
3"	12"

	CABLE ROUTE MARKER	
	2000	UM12

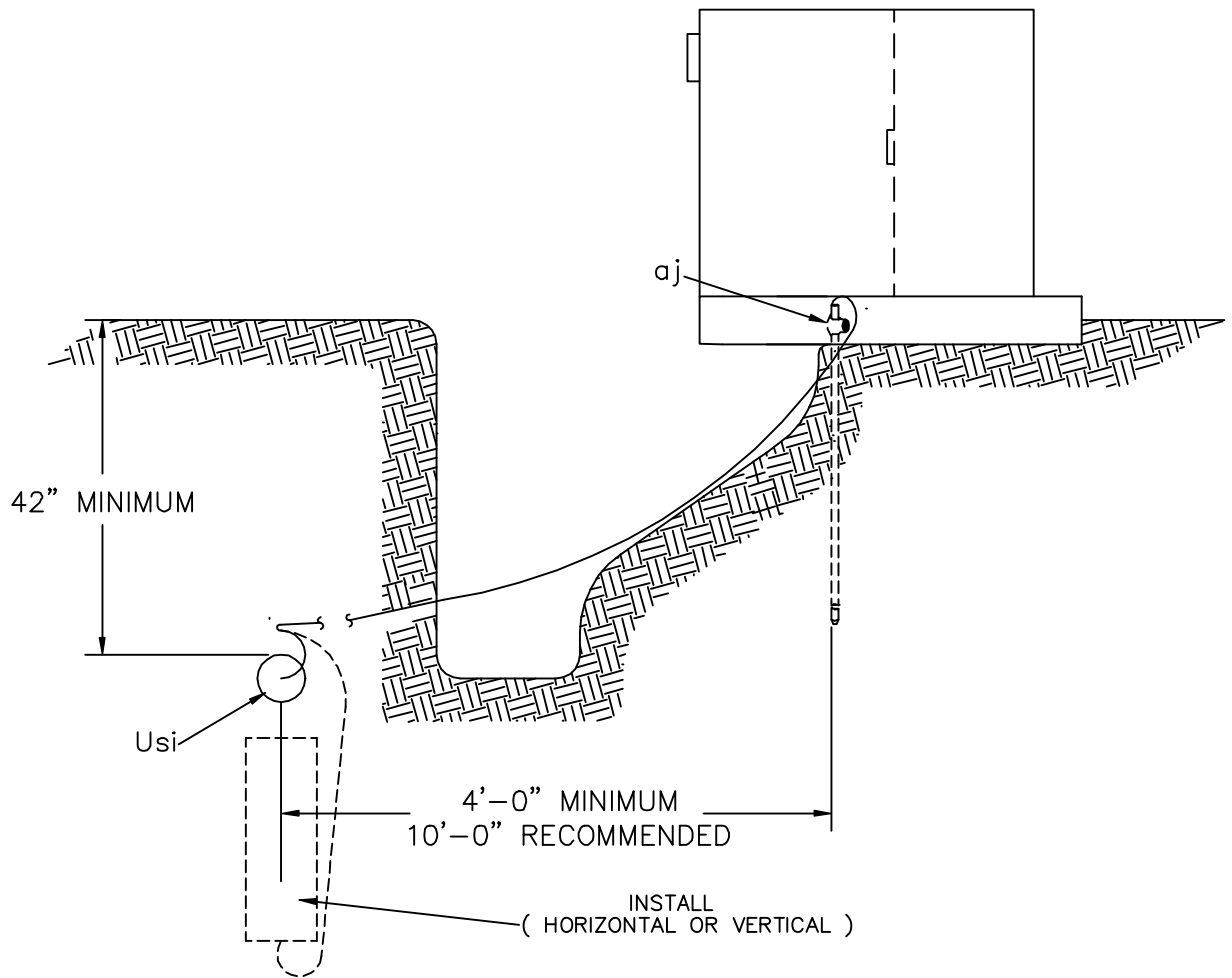

NOTE:

1. CONNECT ANODE LEAD WIRE INSIDE PADMOUNTED EQUIPMENT TO ENABLE TESTING OF ANODE OUTPUT.

ITEM	QTY.	MATERIAL		
p		Connectors, compression, as required		
aj		Clamps, ground rod, as required	SACRIFICIAL ANODE FOR EQUIPMENT GROUND PROTECTION	
Usi		Anode, sacrificial, as required		
			2000	UM27-2

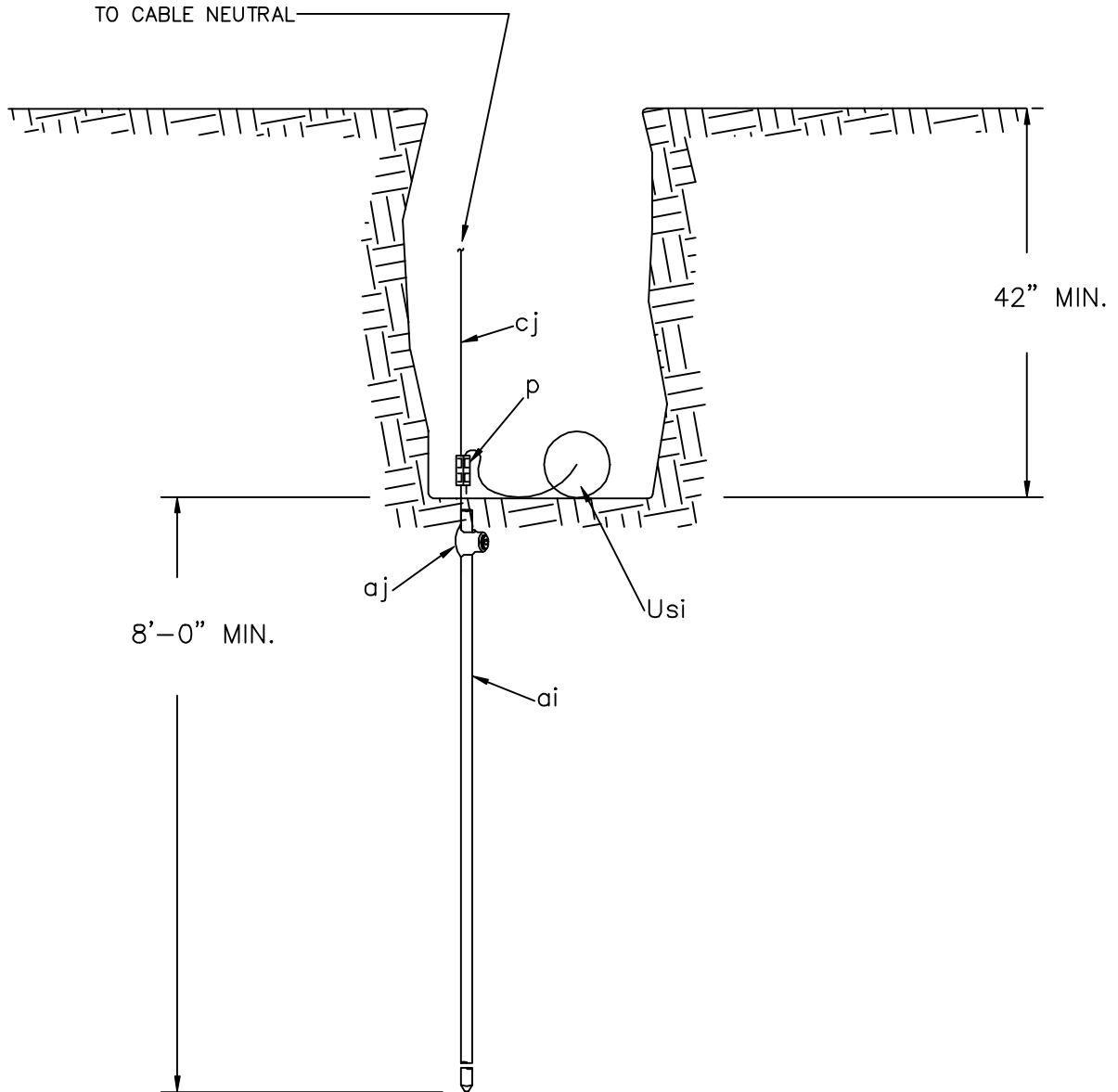

NOTES:

1. INSTALLATION OF AN ANODE IS NOT REQUIRED AT ALL GROUNDING LOCATIONS.
2. ROUTE ANODE LEAD SO AS TO BE ACCESSIBLE FOR TESTING WHENEVER FEASIBLE. (SEE UNITS UM28 OR UM28-1.)

ITEM	QTY.	MATERIAL
p	1	Connector, compression
ai	1	Ground rod, 5/8" x 8'-0" Copper clad
aj	1	Clamp, ground rod
cj		Ground wire, #6 S.D. copper (min.)
Usi	1	Anode, sacrificial

SACRIFICIAL ANODE
FOR
CABLE GROUND PROTECTION

2000

UM27-3

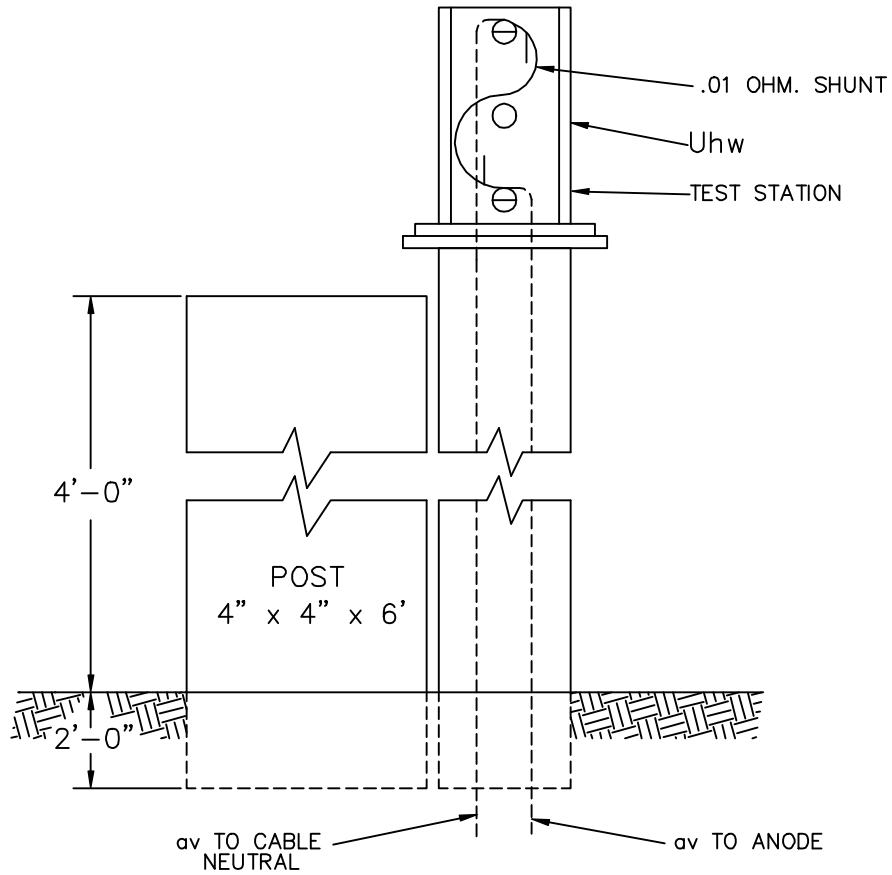

UM28 ABOVE GROUND LEVEL.

UM28-1 FLUSH WITH GROUND LEVEL
(DELETE POST AND ADD SUITABLE METHOD
FOR LOCATING.)

NOTE:

CONNECTIONS TO BE MADE IN ACCORDANCE WITH MANUFACTURER'S INSTRUCTIONS.

ITEM	QTY.	MATERIAL		
	1	4" x 4" x 6' Treated post		
	1	Test station, anode		
	1	Shunt, anode		
av		Jumper, insulated, as required	TEST STATION	
Uhw	1	Sign, "WARNING"	2000	UM28

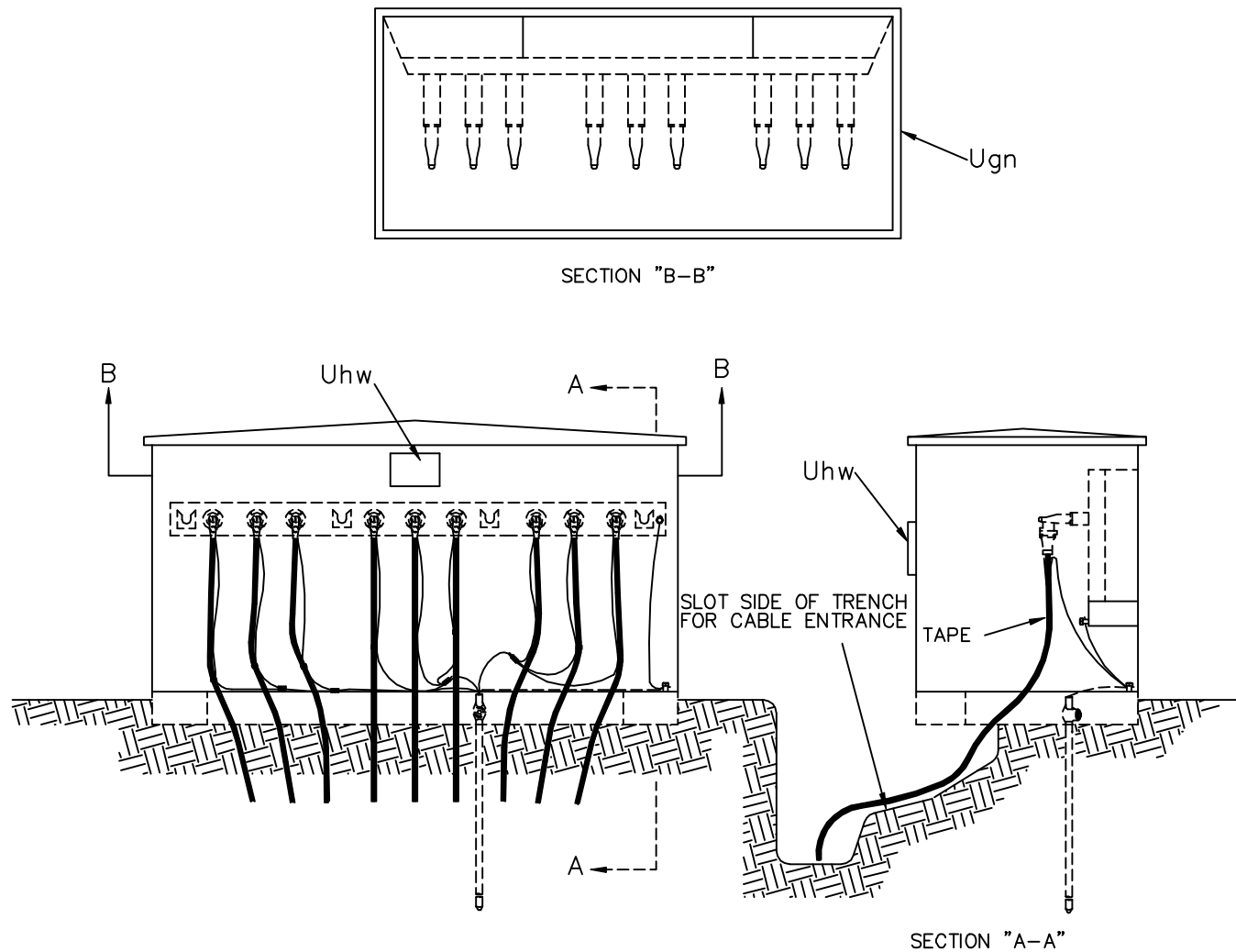

NOTES:

1. THE FOLLOWING UNITS/ASSEMBLIES ARE NOT PART OF THIS UNIT. SPECIFY SEPARATELY:
 - A. MULTIPOINT TERMINATIONS AND OTHER ACCESSORIES
 - B. FUSED OR NON-FUSED LOADBREAK ELBOWS
 - C. GROUNDING ASSEMBLIES UM48-1 OR OTHER
 - D. PAD OR SLEEVE ASSEMBLIES (IF REQUIRED)

2. ALL NEUTRALS AND METALLIC NON-CURRENT CARRYING PARTS SHALL BE INTERCONNECTED AND GROUNDED.

3. INSTALL "WARNING" SIGN ON OUTSIDE SURFACE OF ENCLOSURE AND "DANGER" SIGN INSIDE ENCLOSURE.

ITEM	QTY.	MATERIAL			
p		Connectors, as required			
av		Jumpers, as required			
Ugn	1	Enclosure	MULTI PHASE SECTIONALIZING ENCLOSURE PAD OR SLEEVE MOUNTED		
Uhw	2	Signs, "DANGER" and "WARNING"			
			2000	UM33	

TRANSFORMER INSTALLATION
(FRONT VIEW)

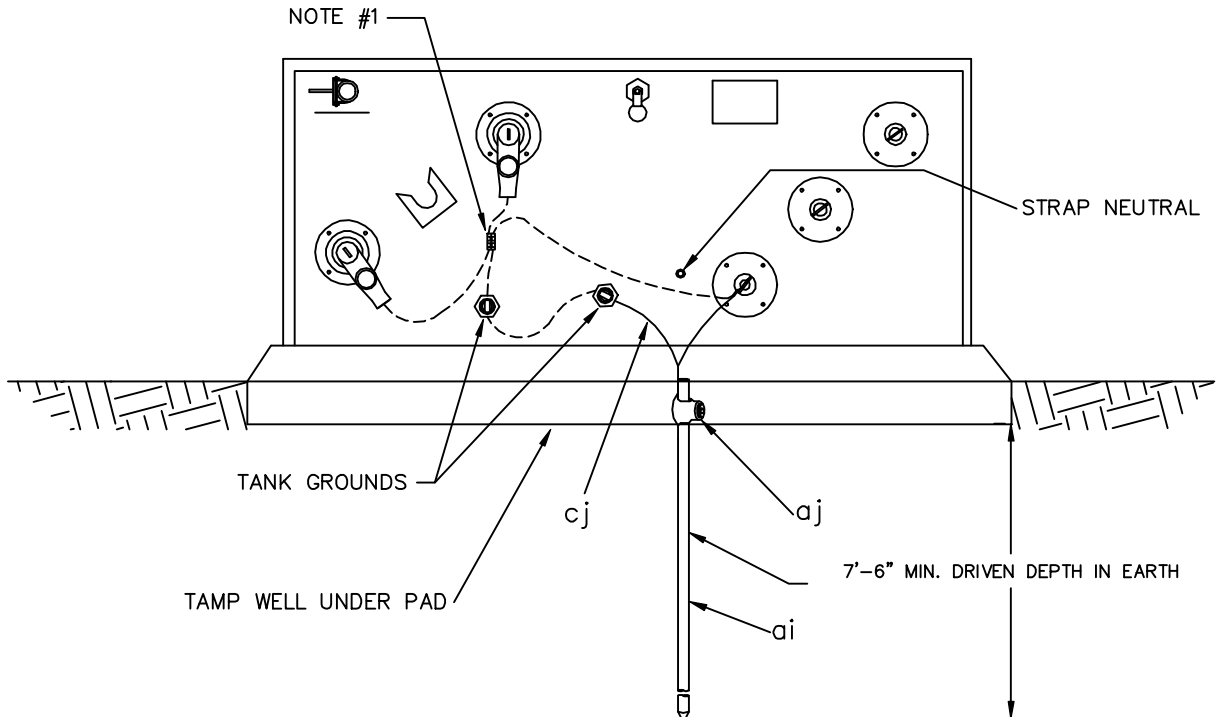

DEADFRONT FUSE ENCLOSURE
(TOP VIEW)

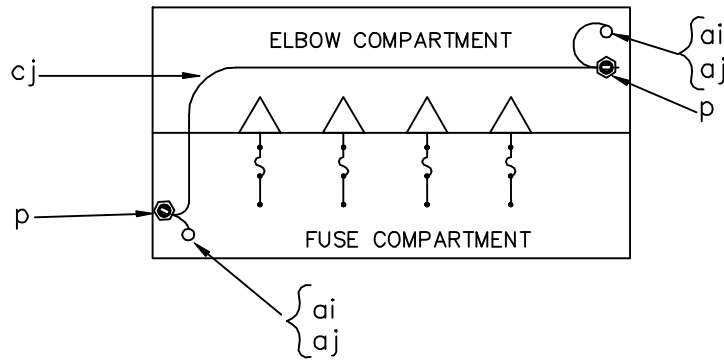

NOTES:

1. TIE CONCENTRIC NEUTRALS TOGETHER BEFORE TAP TO GROUND LOOP TO ASSURE SAME CONDUCTIVITY AS CABLE NEUTRAL.

ITEM	QTY	MATERIAL
p		Connectors, (as required)
ai		Ground rods, specify number and length
aj		Clamp, ground rod (1 per rod)
cj		Ground wire, #4 copper (as required)

GROUNDING ASSEMBLY FOR PAD MOUNTED SINGLE PHASE TRANSFORMERS AND ENCLOSURES		
	2000	UM48-1

TRANSFORMER INSTALLATION
(FRONT VIEW)

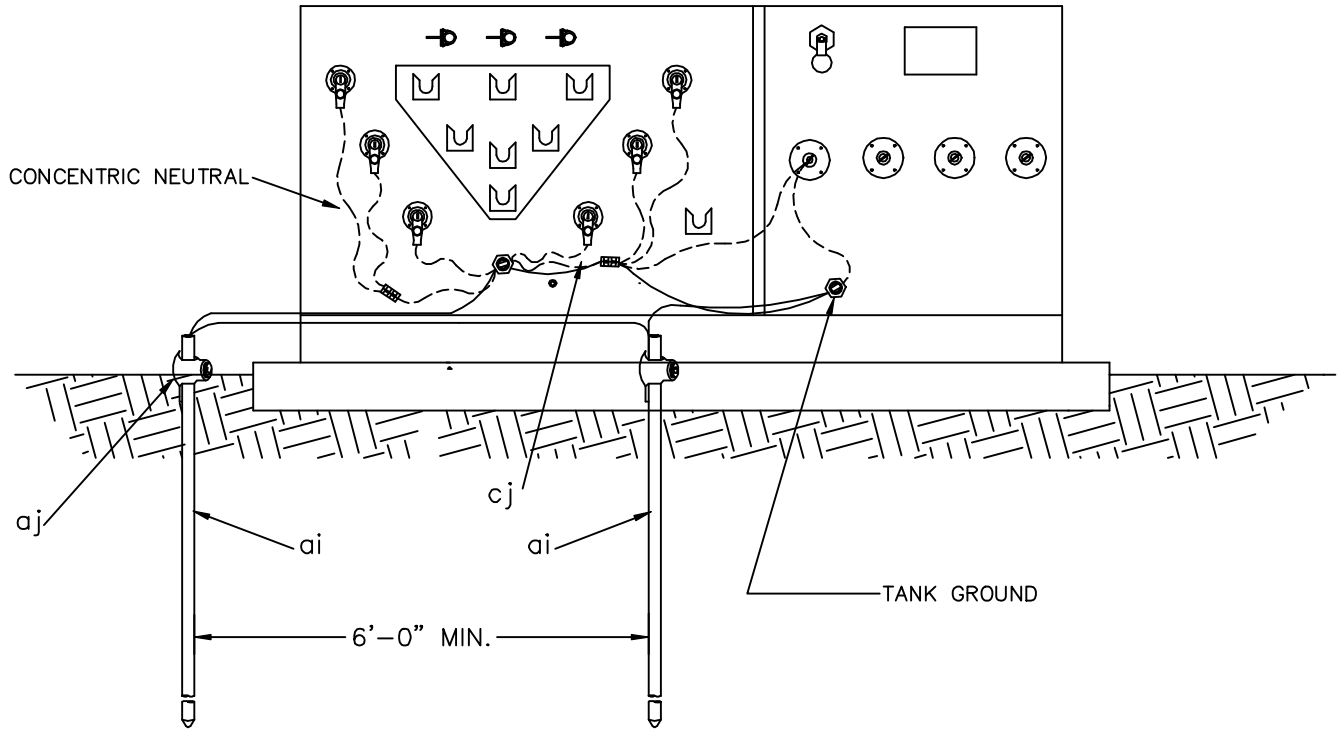

DEAD FRONT FUSE ENCLOSURE
(TOP VIEW)

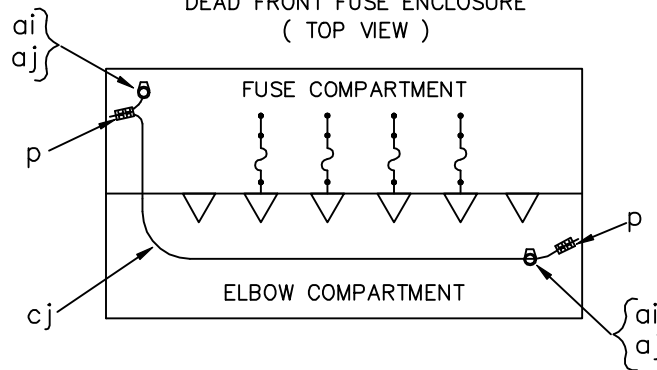

NOTES:

1. TIE CONCENTRIC NEUTRALS TOGETHER BEFORE TAP TO GROUND LOOP TO ASSURE SAME CONDUCTIVITY AS CABLE NEUTRAL.
2. MULTIPLE RODS MAY NOT FIT INSIDE ENCLOSURE. ONLY 1 ROD MUST BE INSTALLED INSIDE ENCLOSURE.
3. THE QUANTITY OF RODS IS TO BE DETERMINED BY THE SPECIFIER. THE USE OF TWO RODS RATHER THAN ONE AT A MULTI-PHASE TRANSFORMER OR ENCLOSURE IS NOT A STANDARD OR REQUIREMENT BY RUS.

ITEM	QTY	MATERIAL
p		Connectors, as required
ai		Ground rods, specify number and length
aj		Clamp, ground rod (1 per rod)
		Jumpers, copper, as required
cj		Ground wire, #4 copper min. (as required)

GROUNDING ASSEMBLY FOR
PAD MOUNTED MULTI PHASE
TRANSFORMERS AND ENCLOSURES

2000

UM48-2

NOTES:

1. #2 THRU 4/0 CONDUCTOR - USE #4 BARE, SOLID CU JUMPER (av) #4 STRD CU GROUND WIRE (cj) 500 MCM CONDUCTOR - USE #2/0 BARE SOLID CU JUMPER (av) #2 STRD CU GROUND WIRE (cj).
2. ENGINEER TO SPECIFY NUMBER AND LENGTH OF GROUND RODS.
3. MOISTURE SEAL AROUND CONNECTIONS TO THE JACKETED CABLE NEUTRAL. USE SOLID COPPER INSIDE AND EXTENDED THROUGH MOISTURE SEAL.
4. FOUR GROUNDS PER MILE MINIMUM. MORE REQUIRED WITH HIGH GROUND RESISTANCE.
5. GROUND RODS MAY BE INSTALLED IN SEPARATE PITS SPACED 30 FEET APART.

SEE NOTE #1
cj

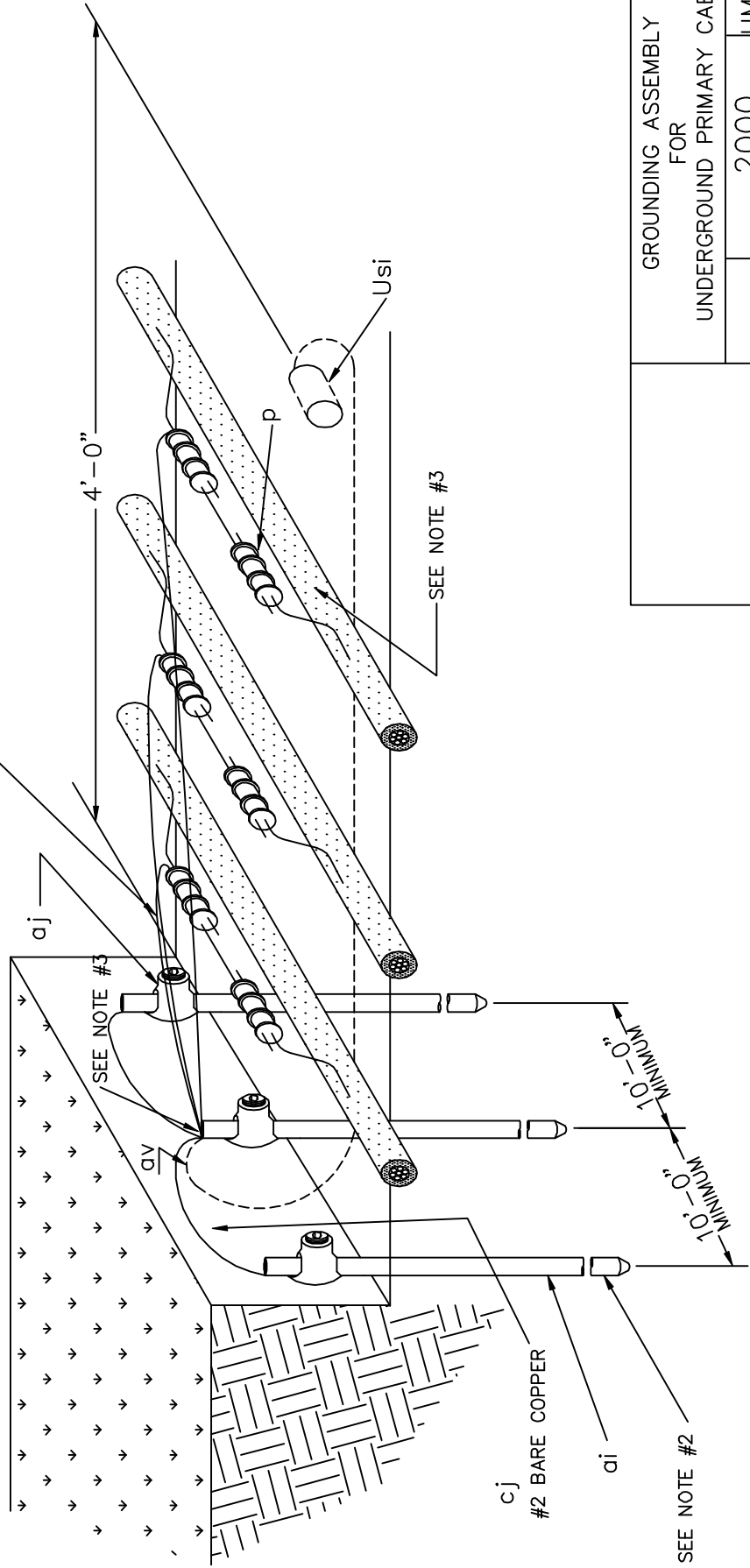

ITEM	QTY.	MATERIAL
p		Connector, compression as required
ai		Ground rods
aj		Clamp, ground rod, as required
av		Jumper, See Note #1
cj		Grounding wire, #4, #2, copper
cj		Jumpers, (2) - #14 stranded leads

GROUNDING ASSEMBLY FOR UNDERGROUND PRIMARY CABLE	
2000	UM48-3

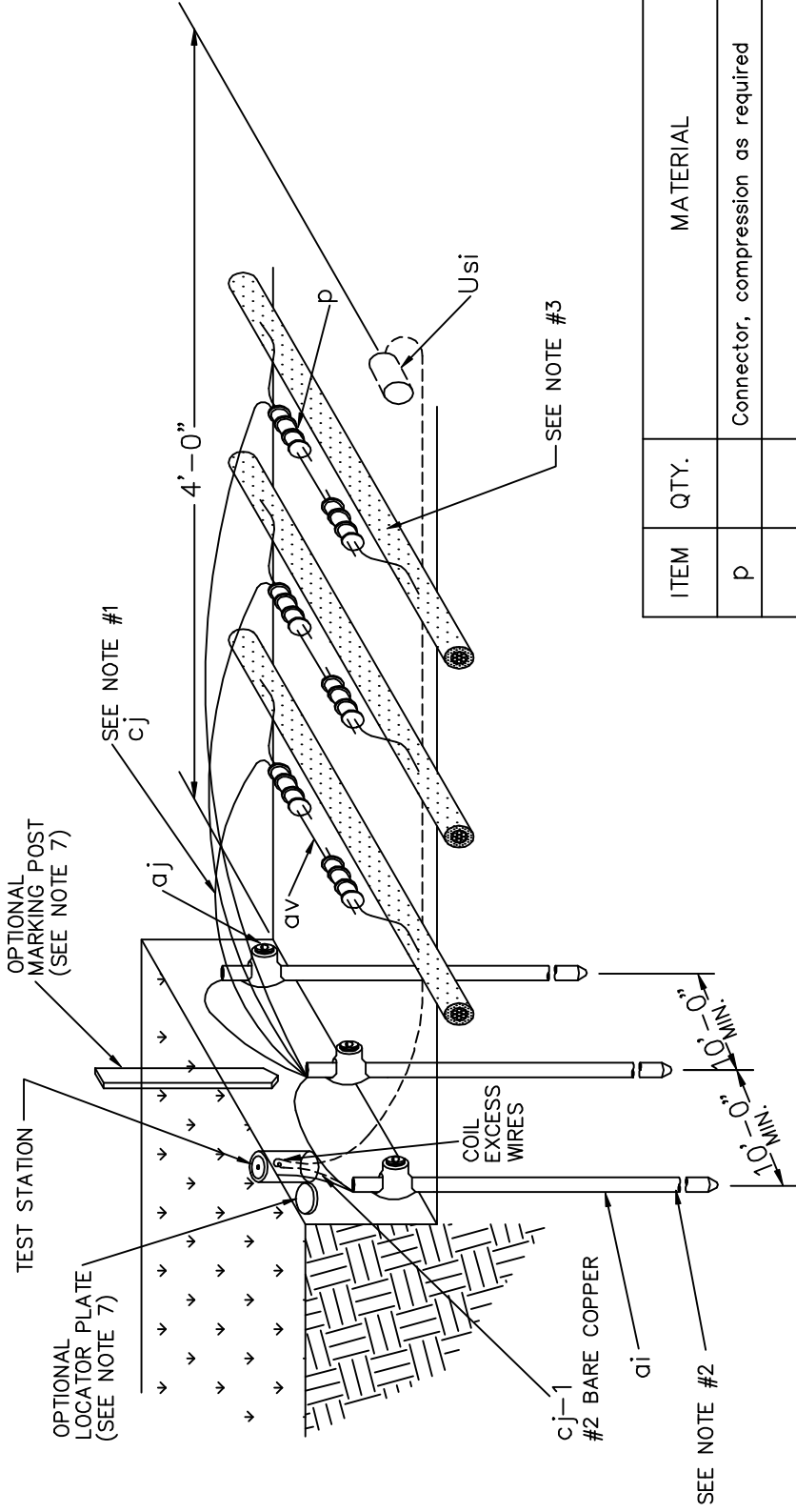

NOTES:

1. #2 THRU 4/0 CONDUCTOR - USE #4 BARE, SOLID CU. JUMPER (av) #4 STRD. CU. GROUND WIRE (cj) 500 MCM CONDUCTOR - USE #2/0 BARE, SOLID CU. JUMPER (av) #2 STRD. CU. GROUND WIRE (cj).
2. ENGINEER TO SPECIFY NUMBER AND LENGTH OF GROUND RODS.
3. MOISTURE SEAL AROUND CONNECTIONS TO THE JACKETED CABLE NEUTRAL. USE SOLID COPPER INSIDE EXTENDED THROUGH MOISTURE SEAL.
4. FOUR (4) GROUNDS PER MILE MINIMUM. MORE REQUIRED WITH HIGH GROUND RESISTANCE.
5. INSTALL TEST STATION EVEN WITH GRADE.
6. GROUND RODS MAY BE INSTALLED IN SEPARATE PITS SPACED 30 FEET APART.
7. SEE DRAWING UX-7 FOR POSSIBLE LOCATING METHODS.

ITEM	QTY.	MATERIAL
p		Connector, compression as required
ai		Ground rods
aj		Clamp, ground rod, as required
av		Jumper, copper (See Note #1)
cj		Grounding wire #4, #2, copper
cj		Jumper (2) - #14 stranded leads
	1	Test station, flush mount
		GROUNDING ASSEMBLY FOR UNDERGROUND PRIMARY CABLE (WITH TEST STATION)
		2000
		UM48-4

TOP VIEW

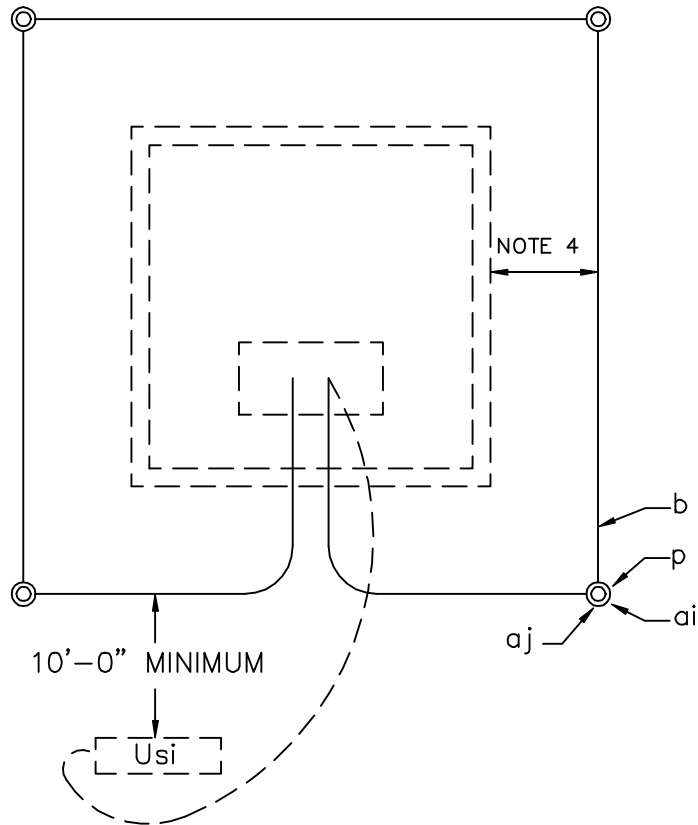

NOTE:

CONNECT ANODE, LEAD INSIDE PAD MOUNTED ENCLOSURES FOR TESTING PURPOSES.

FRONT VIEW

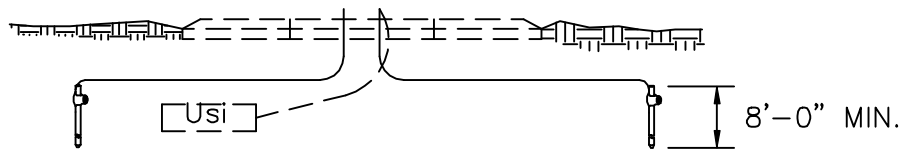

NOTES:

1. PLACE ONE GROUND ROD AT EACH CORNER.
2. GROUNDING GRID 1/0 BARE COPPER BURIED 6" BELOW GROUND, RUN WIRE INTO BASEMENT AND ALLOW 5'-0" FOR GROUNDING LIVE FRONT SWITCH / FUSE ENCLOSURES.
3. PAD OR BASEMENT IS NOT PART OF THIS UNIT.
4. PLACE GROUND WIRE A MINIMUM OF 24" AWAY FROM THE SIDE OR SIDES OF PAD THAT A PERSON WOULD STAND TO OPERATE THE EQUIPMENT. THE GROUND WIRE MAY BE PLACED WITHIN 12" OF THE OTHER SIDES.
5. SPECIFY LENGTH OF GROUND RODS AT EACH CORNER.

ITEM	QTY.	MATERIAL
av		1/0 bare copper (as required) 30'-0" Min.
p		Connectors (as required)
ai	4	Ground rods
aj	4	Clamp, ground rod, 1 per rod

GROUNDING GRID FOR PAD MOUNTED EQUIPMENT INSTALLATION

2000

UM48-5

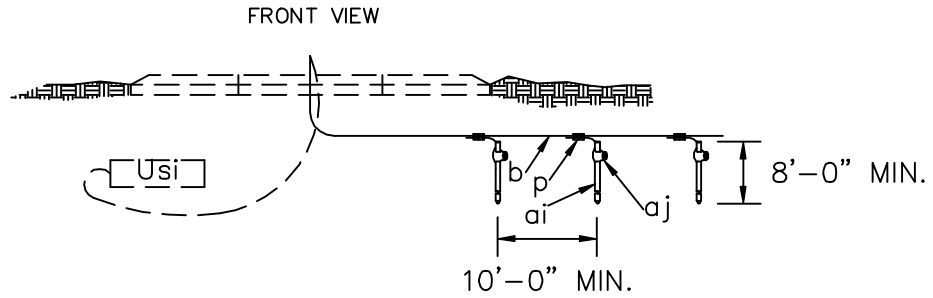

NOTE:
CONNECT ANODE LEAD INSIDE PAD MOUNTED ENCLOSURES FOR TESTING PURPOSES

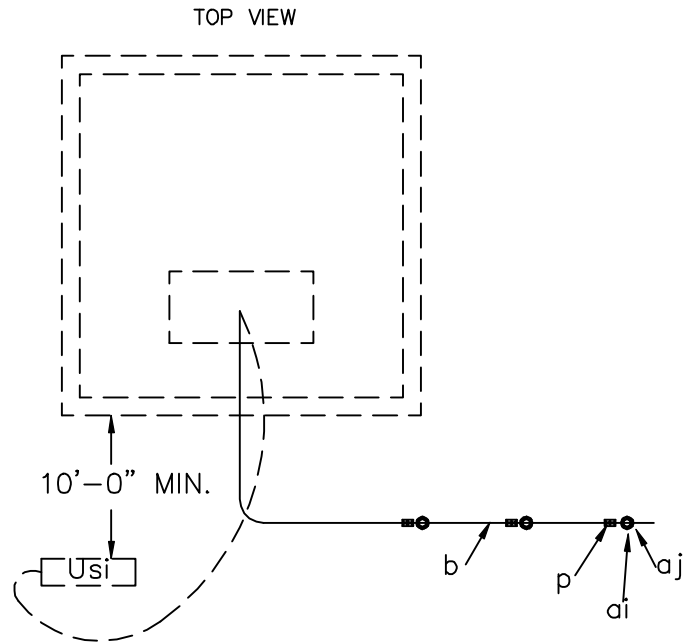

NOTES:

1. PLACE A MINIMUM OF TWO GROUND RODS IN SERIES. MINIMUM DISTANCE BETWEEN GROUND UNIT ASSEMBLIES - 10'-0".
2. GROUNDING GRID 1/0 BARE COPPER BURIED 6" BELOW GROUND, RUN WIRE INTO BASEMENT AND ALLOW 5'-0" FOR GROUNDING LIVE FRONT SWITCH / FUSE ENCLOSURES.
3. PAD OR BASEMENT IS NOT PART OF THIS UNIT.
4. SPECIFY NUMBER AND LENGTH OF GROUND RODS.

ITEM	QTY.	MATERIAL		
av		1/0 bare copper as required	GROUNDING ARRAY FOR PAD MOUNTED EQUIPMENT INSTALLATION	
p		Connectors, as required		
ai		Ground rods		
aj		Clamp, ground rod, 1 per rod		
			2000	UM48-6

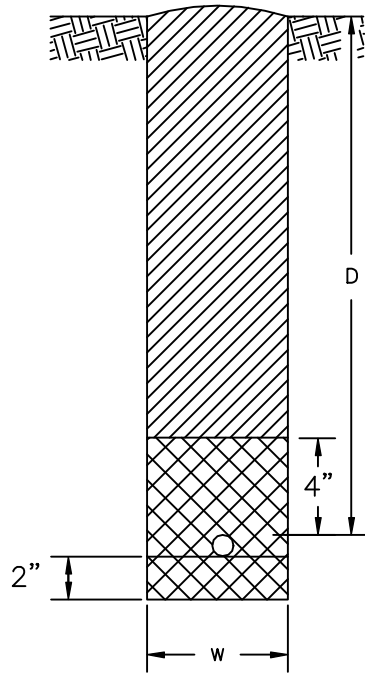

UR2 (D x W)
TRENCHING UNIT
ONE CABLE OR
CABLE ASSEMBLY

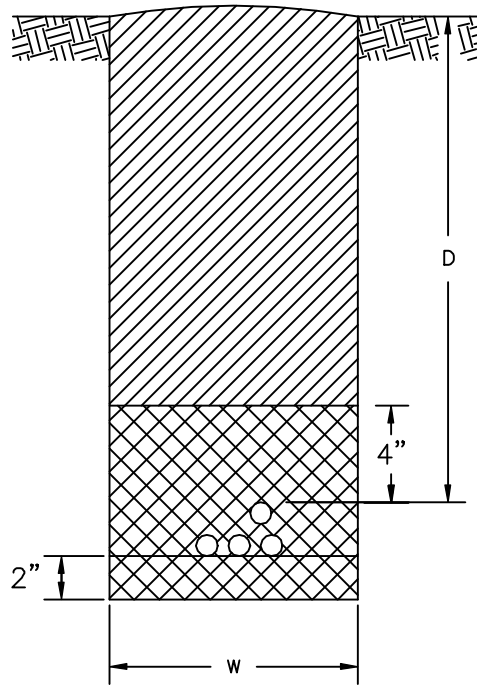

UR2-1 (D x W)
TRENCHING UNIT
MULTIPLE POWER CABLES
PRIMARY, SECONDARY OR SERVICE

LEGEND



SAND OR CLEAN SOIL

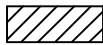

COMPACTED BACKFILL UNLESS OTHERWISE SPECIFIED



UNDISTURBED EARTH

NOTES:

1. DEPTH (D) AND WIDTH (W) ARE SPECIFIED IN DESCRIPTION OF UNITS.
2. DEPTHS SPECIFIED ARE TO FINISHED GRADE.
3. OVER-EXCAVATE TRENCHES AS NECESSARY TO ALLOW FOR (a) SAND BEDDING OR (b) LOOSE SANDY SOILS OR (c) WHERE MORE THAN ONE CABLE WILL INSTALLED IN TRENCH AND LAYING FIRST CABLE MAY CAUSE TRENCH DAMAGE AND REDUCTION IN DEPTH.
4. SAND BEDDING IS NOT PART OF THESE UNITS AND WILL BE SPECIFIED AS NEEDED.
5. BACKFILLING IS PART OF ALL TRENCHING UNITS INCLUDING JOINT-USE TRENCHES.
6. OPTIONAL WARNING TAPE IS RECOMMENDED TO BE PLACED ABOVE THE INSTALLED CABLE.

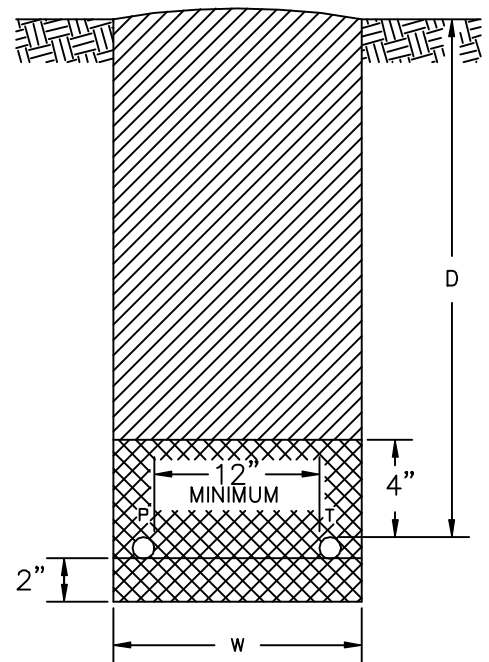

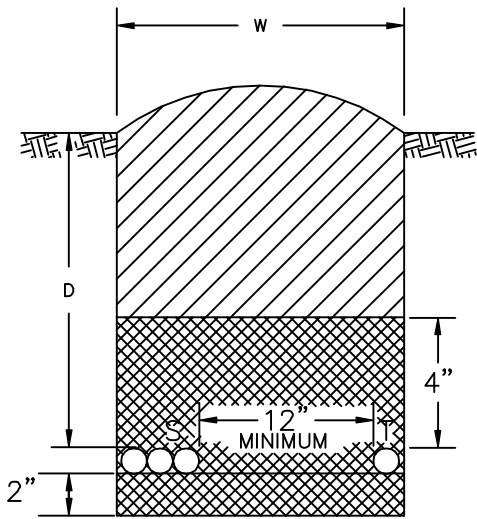

UR2-2 (D x W)
TRENCHING UNIT
POWER AND TELEPHONE CABLE

TRENCHES FOR DIRECT BURIAL CABLES		
	2000	UR2 TO UR2-2



UR2-3 (D x W)
SERVICE OR SECONDARY
AND
TELEPHONE

LEGEND

-  BEDDING SAND OR CLEAN SOIL
-  COMPACTED BACKFILL UNLESS OTHERWISE SPECIFIED
-  UNDISTURBED EARTH

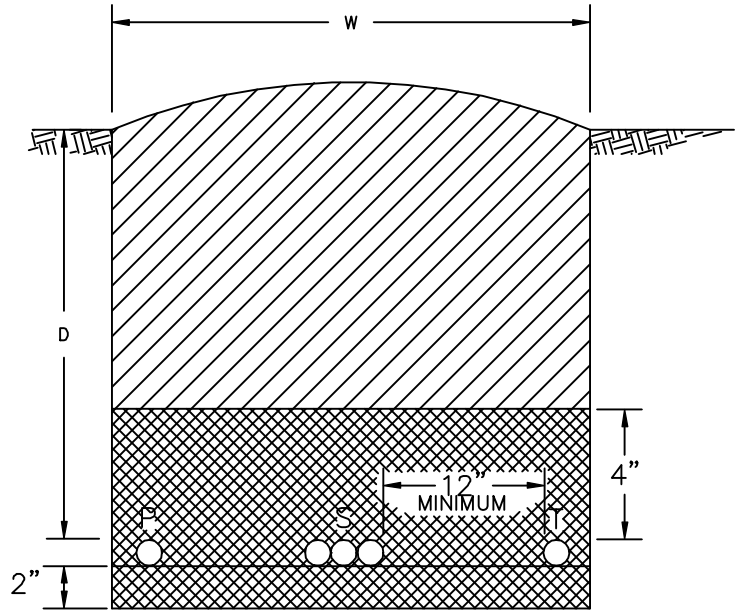

UR2-5 (D x W)
PRIMARY, SECONDARY
AND
TELEPHONE

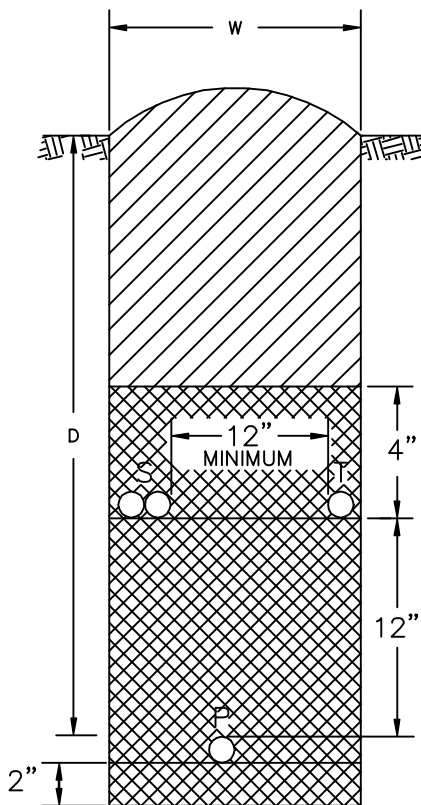

UR2-4 (D x W)
PRIMARY
AND
SECONDARY OR TELEPHONE

NOTES:

1. DEPTH (D) AND WIDTH (W) ARE SPECIFIED IN DESCRIPTION OF UNITS.
2. DEPTHS SPECIFIED ARE TO FINISHED GRADE.
3. OVER-EXCAVATE TRENCHES AS NECESSARY TO ALLOW FOR (a) SAND BEDDING OR (b) LOOSE AND SANDY SOILS OR (c) WHERE MORE THAN ONE CABLE WILL BE INSTALLED IN TRENCH AND LAYING OF FIRST CABLE MAY CAUSE TRENCH DAMAGE AND REDUCTION IN DEPTH.
4. SAND BEDDING IS NOT PART OF THESE UNITS AND WILL BE SPECIFIED AS NEEDED.
5. BACKFILLING IS PART OF ALL TRENCHING UNITS INCLUDING JOINT-USE TRENCHES.

TRENCHES FOR DIRECT BURIAL CABLES		
	2000	UR2-3 TO UR2-5

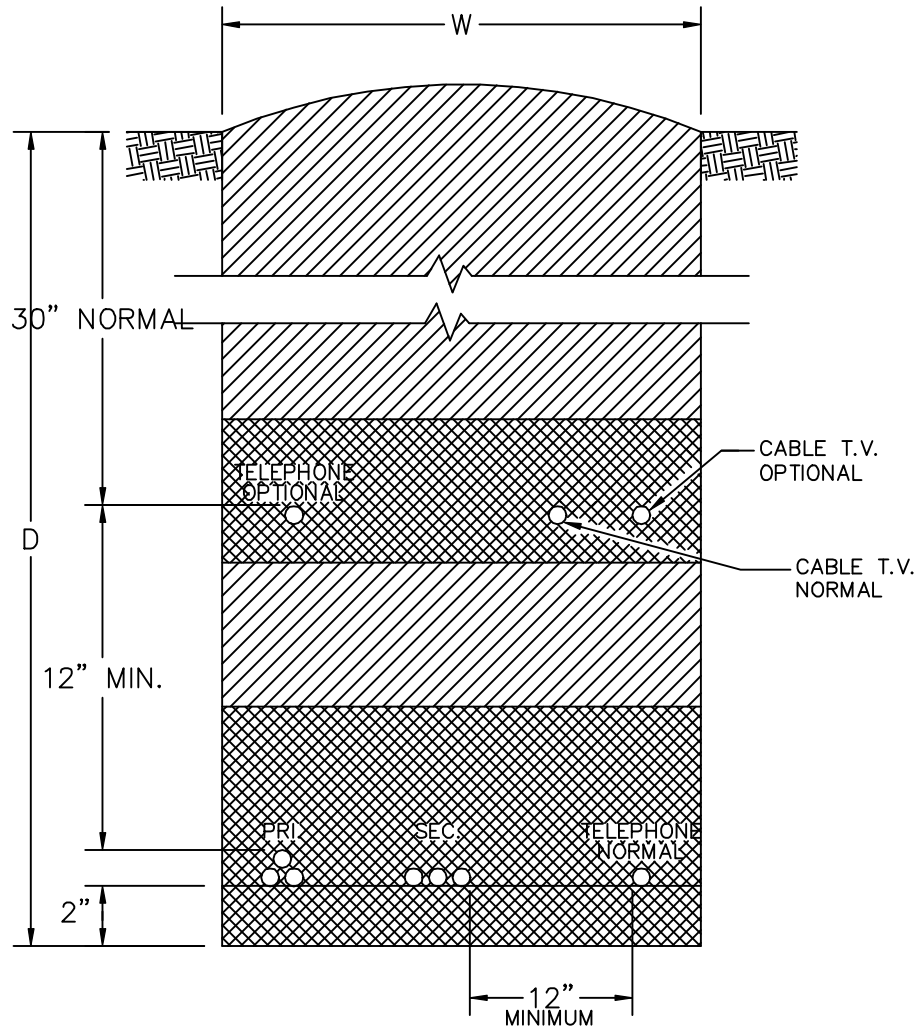

LEGEND

BEDDING SAND OR CLEAN SOIL

COMPACTED BACKFILL UNLESS OTHERWISE SPECIFIED

UNDISTURBED EARTH

PRI. = PRIMARY SUPPLY CABLES
SEC. = SECONDARY OR STREETLIGHT WIRES

URT-NT = NORMAL TRENCH 42" - 48" DEPTH
URT-ST = SUPER TRENCH 60" + DEPTH
W = 18" - 24" NORMAL

NOTES:

1. DEPTH (D) AND WIDTH (W) ARE SPECIFIED IN DESCRIPTION OF UNITS.
2. DEPTHS SPECIFIED ARE TO FINISHED GRADE.
3. OVER-EXCAVATE TRENCHES AS NECESSARY TO ALLOW FOR (a) SAND BEDDING OR (b) LOOSE AND SANDY SOILS OR (c) WHERE MORE THAN ONE CABLE WILL BE INSTALLED IN TRENCH AND LAYING OF FIRST CABLE MAY CAUSE TRENCH DAMAGE AND REDUCTION IN DEPTH.
4. SAND BEDDING IS NOT PART OF THESE UNITS AND WILL BE SPECIFIED AS NEEDED.
5. BACKFILLING IS PART OF ALL TRENCHING UNITS INCLUDING JOINT-USE TRENCHES.

		TRENCHES FOR DIRECT BURIAL CABLE	
	2000	UR2-NT	UR2-ST

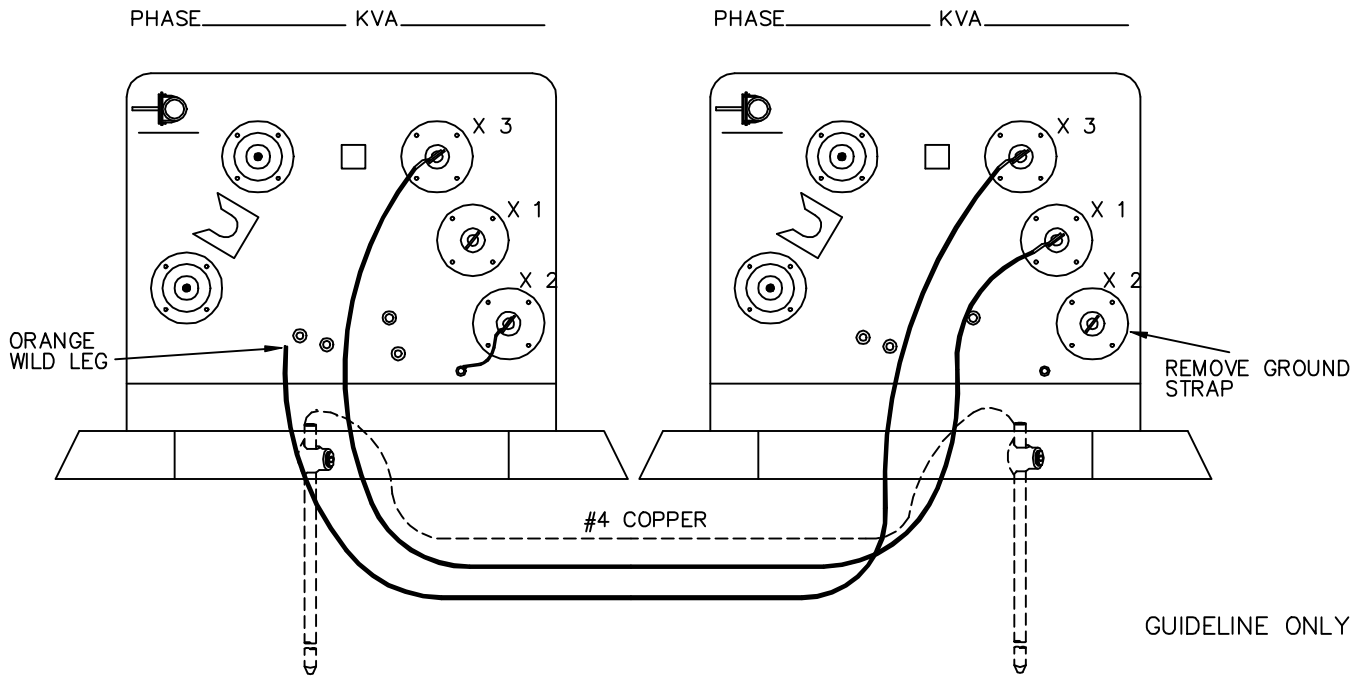
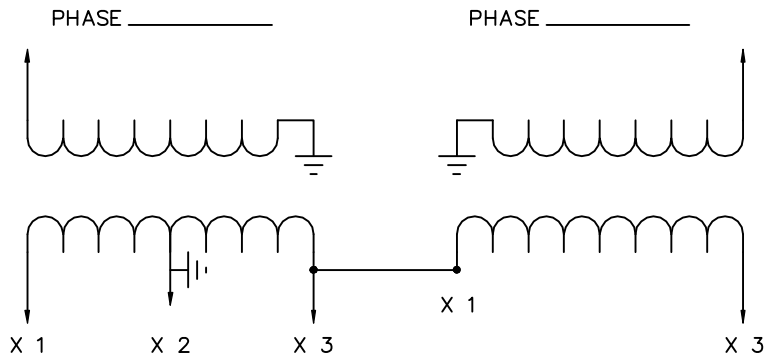

NOTE:

1. SPECIFY (2) APPLICABLE SINGLE PHASE TRANSFORMER ASSEMBLIES.

OPEN DELTA CONNECTION WITH SINGLE PHASE PADMOUNT TRANSFORMERS		
	2000	UX1

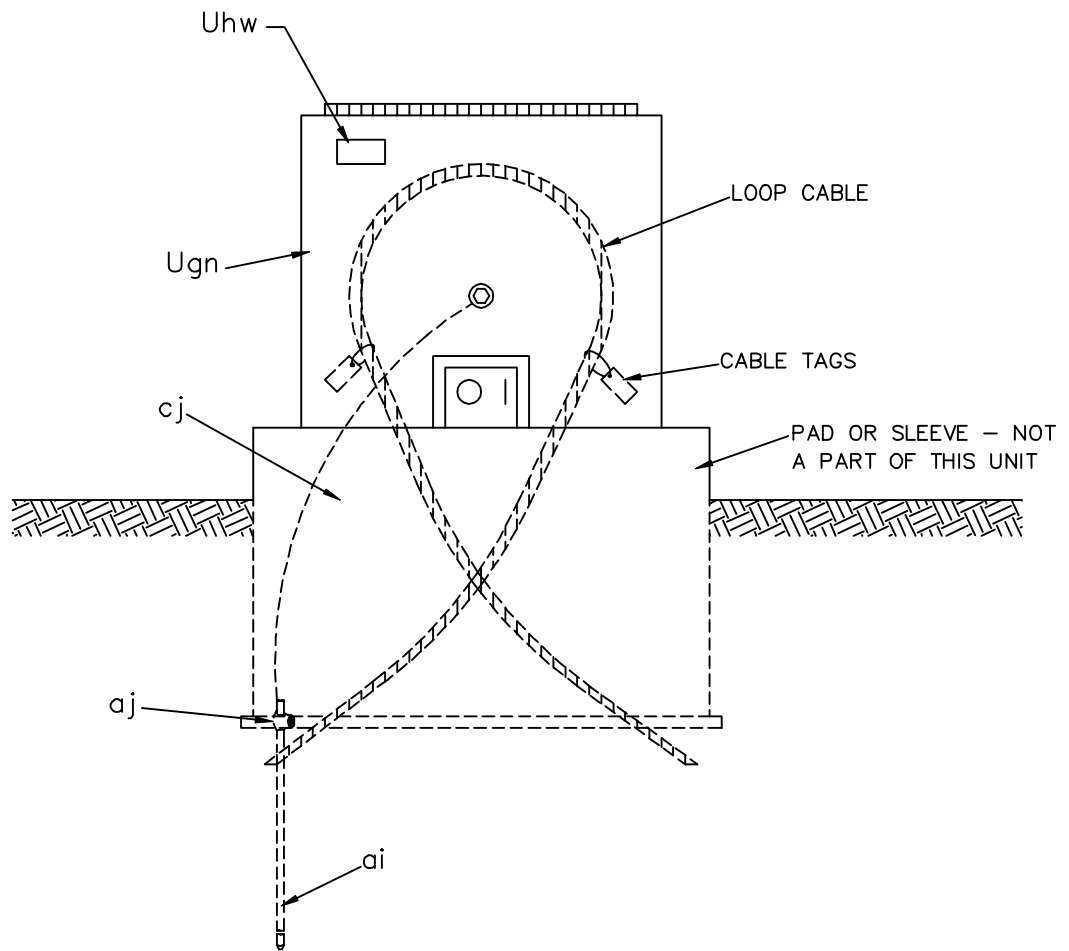

INSTALLATION NOTES:

1. LOOP CABLE TO PROVIDE SUFFICIENT LENGTH FOR TERMINATING IN A PAD-MOUNTED TRANSFORMER.
2. INSTALL CABLE TAGS ON CABLE.

ITEM	QTY.	MATERIAL			
ai	1	Ground rod			
aj	1	Clamp, ground rod			
cj		As required			
Ugn	1	Primary junction enclosure	SINGLE PHASE PAD-MOUNTED TRANSFORMER DEFERRED UNIT PEDESTAL TYPE		
Uhw	1	Sign, "WARNING"			

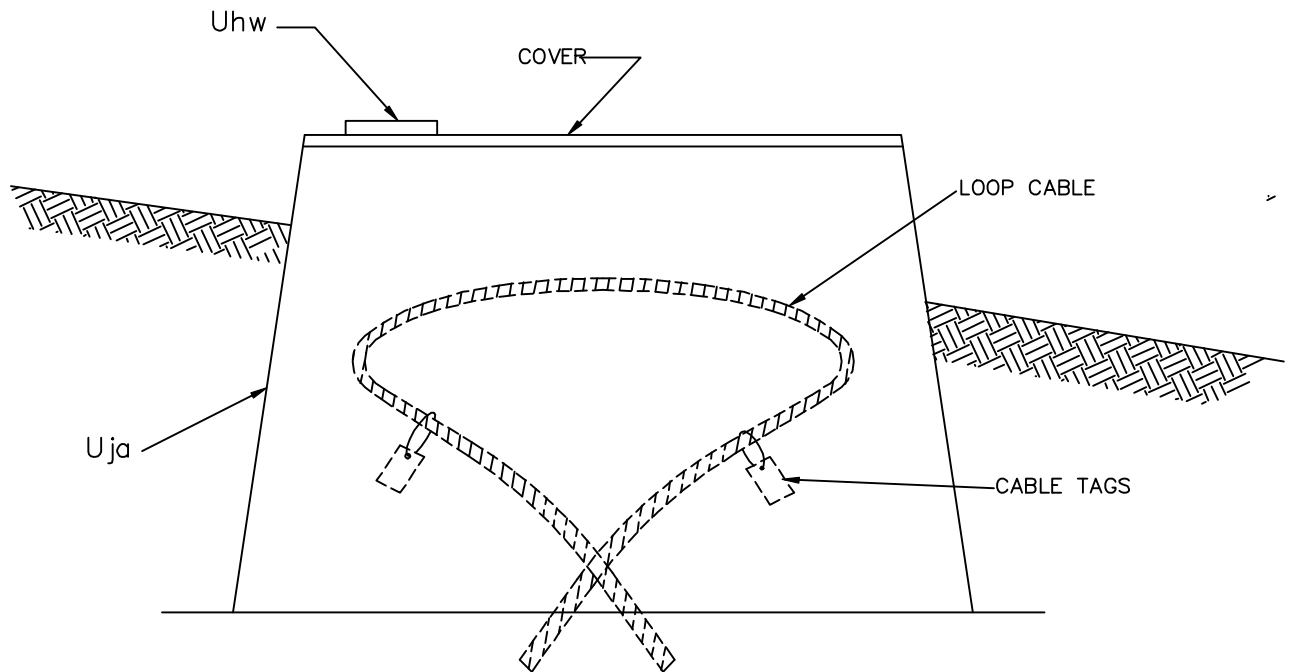

INSTALLATION NOTES:

1. LOOP CABLE TO PROVIDE SUFFICIENT LENGTH FOR TERMINATING IN A LOW PROFILE TRANSFORMER.
2. INSTALL CABLE TAGS ON CABLE.
3. COVER, IF METAL, SHALL BE GROUNDED

ITEM	QTY.	MATERIAL			
Uhw	1	Sign, "WARNING"	SINGLE PHASE PADMOUNTED TRANSFORMER DEFERRED UNIT PAD-SLEEVE TYPE		
Uja	1	Transformer pad-sleeve combination			
Uja	1	Cover			
			2000	UX3	

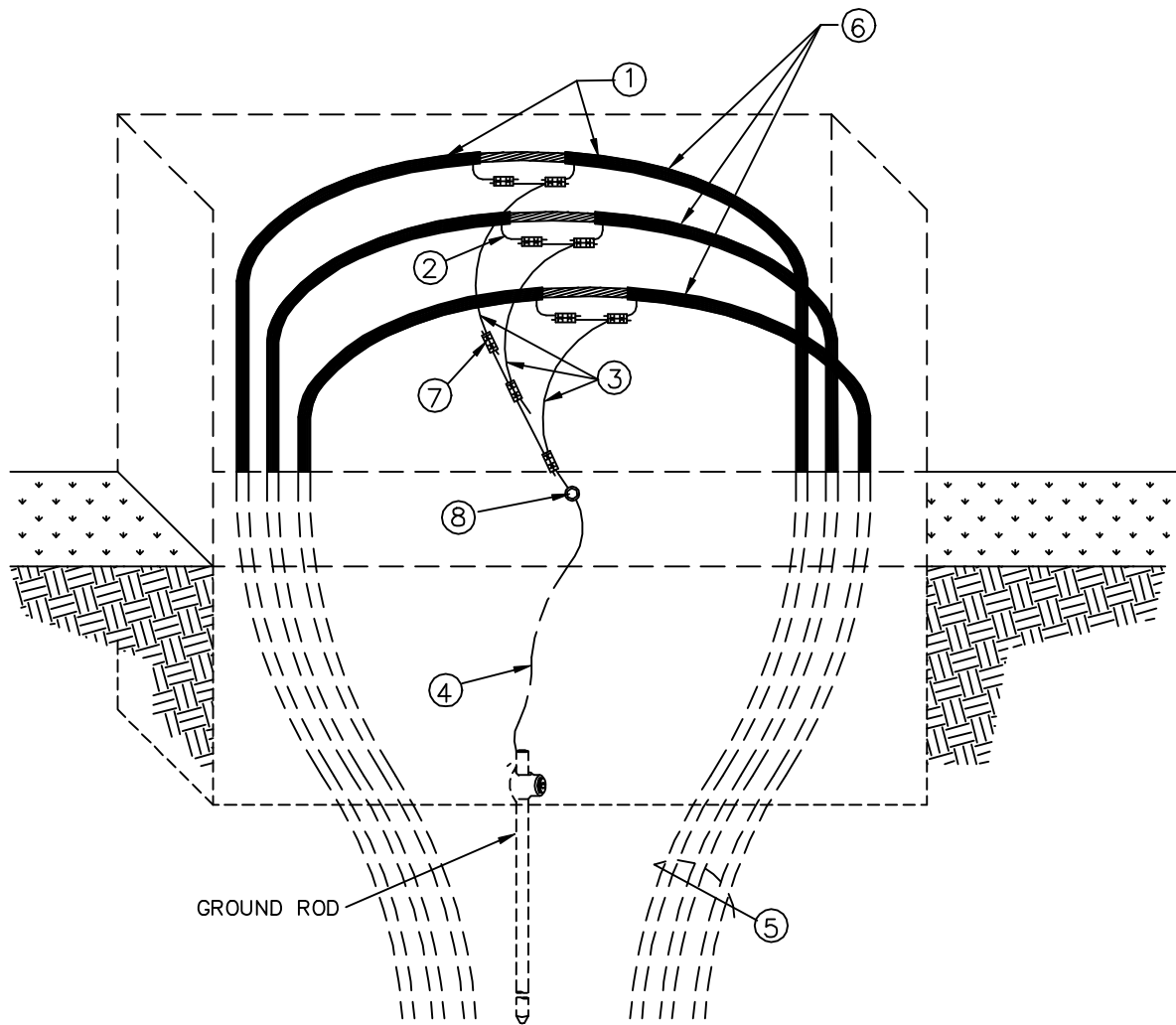

REFERENCE NO.	MATERIAL
①	Label cable for direction leaving sectionalizer
②	Seal cable
③	Neutral extension
④	Ground bus
⑤	Leave sufficient slack in cable for future terminating
⑥	Label cable per phase (A, B or C)
⑦	Parallel compression connector
⑧	Box grounding connector

GUIDELINE ONLY

INSTALLATION OF
NEUTRAL CONNECTION IN
ABOVE GRADE PEDESTAL

2000

UX4

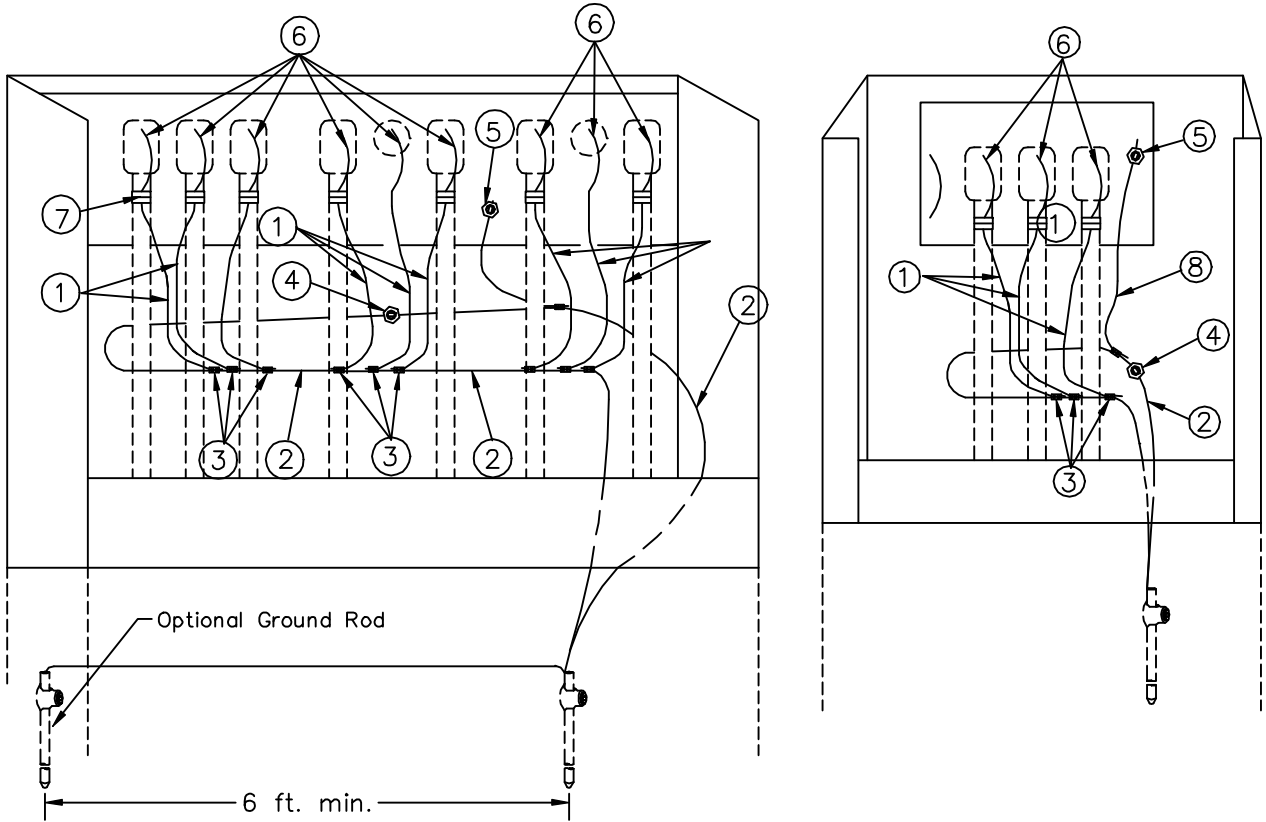

NOTE:

1. LEAVE SUFFICIENT SLACK IN NEUTRAL EXTENSION AND GROUND BUS TO FACILITATE REMOVAL AND PARKING OF PRIMARY CABLES.
2. MULTIPLE GROUND RODS MAY NOT FIT INSIDE ENCLOSURE.
3. MULTIPLE GROUND RODS MAY NOT BE NECESSARY.

REFERENCE NO.	MATERIAL
①	Neutral extension
②	Ground bus
③	Parallel compression connector
④	Box grounding connector
⑤	Plate grounding connector
⑥	Bleed wire from elbow termination
⑦	Bleed wire compression connector
⑧	#6 SD CU

GUIDELINE ONLY

SECTIONALIZING PEDESTAL GROUNDING

2000

UX5

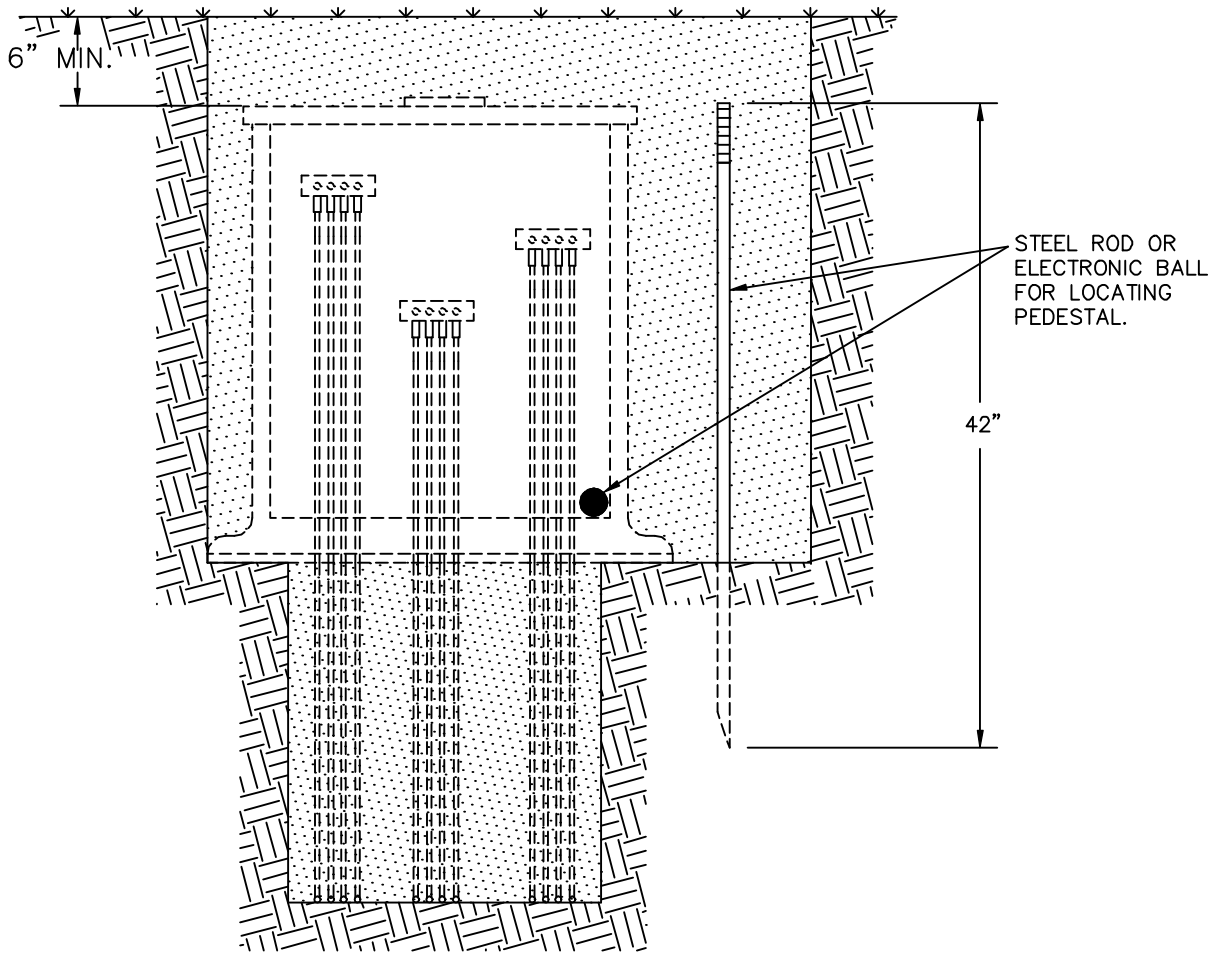

NOTE:

SEE DRAWING UK6

GUIDELINE ONLY

			LOCATION METHODS FOR BELOW GRADE ENCLOSURE	
			2000	UX7

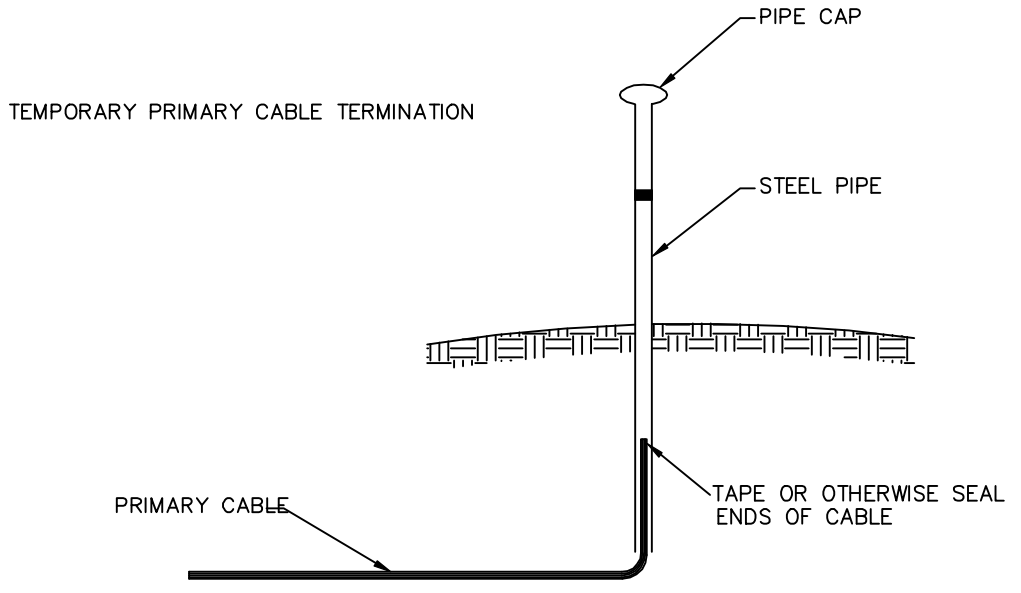

OR

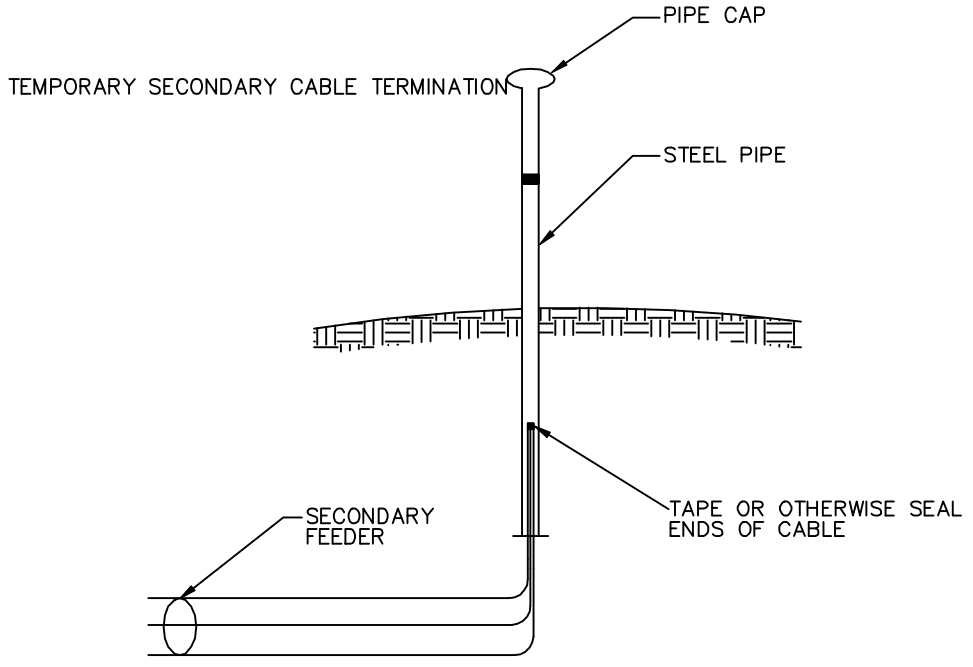

GUIDELINE ONLY

TEMPORARY PRIMARY OR SECONDARY CABLE TERMINATION FOR FUTURE USE		
	2000	UX8

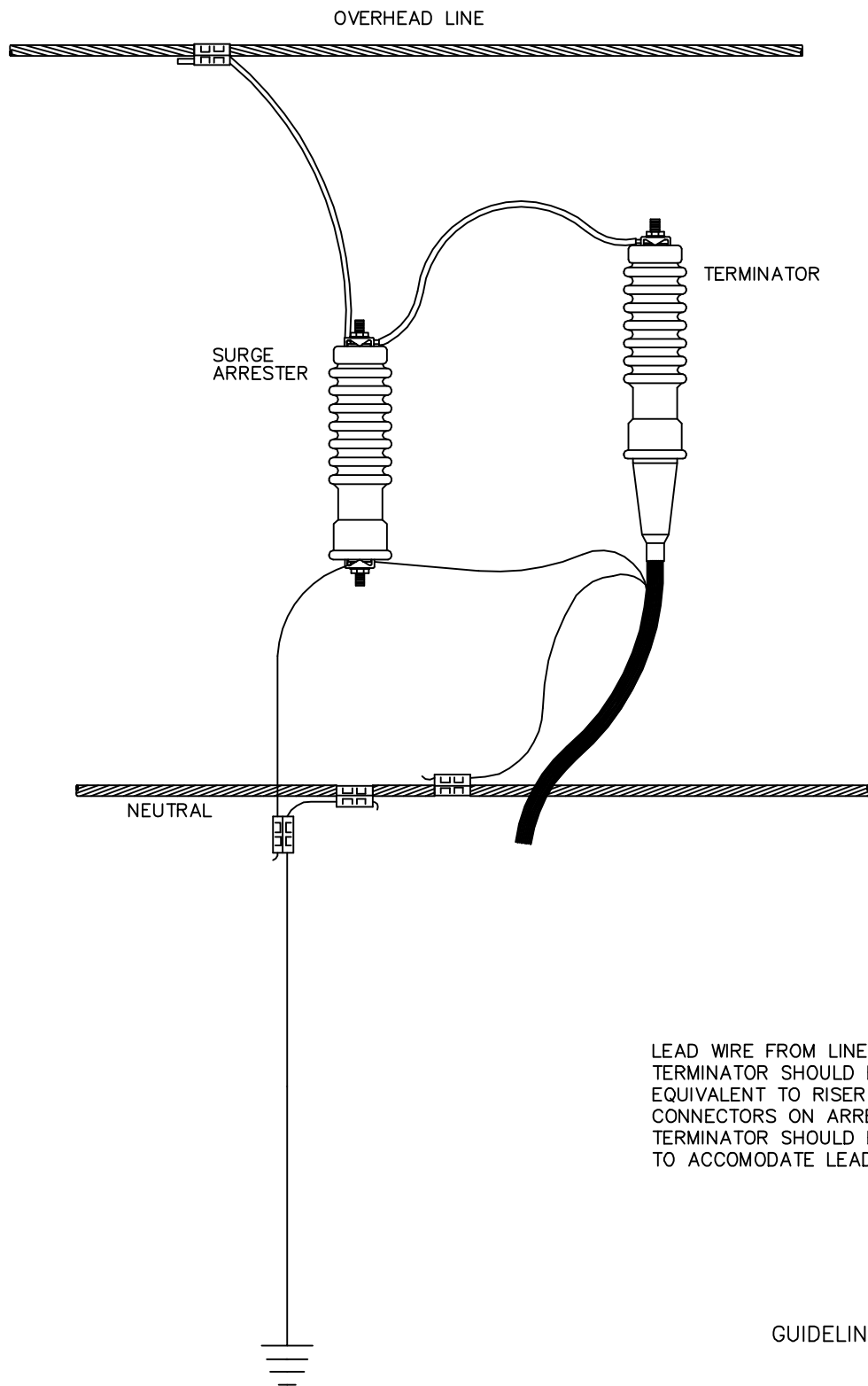

CONNECTION OF TERMINATOR / ARRESTER TO OVERHEAD LINE		
	2000	UX11